

# 2024 COMMERCIAL FURNITURE CATALOGUE

VERTILIFT HEIGHT ADJUSTABLE WORKSTATIONS | COMMERCIAL + HOME OFFICE FURNITURE  
COMMERCIAL SEATING | ACOUSTIC SCREENS | MONITOR ARMS | DESK ACCESSORIES + SOFT-WIRING



NEW EDITION  
SEPTEMBER  
2024



# CONTENTS

<b>VERTILIFT HEAVY DUTY RANGE</b> .....	<b>4</b>
<b>VERTILIFT ROUND LEG RANGE</b> .....	<b>6</b>
<b>VERTILIFT STATIC RANGE</b> .....	<b>8</b>
<b>VERTILIFT COMPONENTS</b> .....	<b>10</b>
<b>VERTILIFT BACK-TO-BACK RANGE</b> .....	<b>12</b>
<b>BACK-TO-BACK COMPONENTS</b> .....	<b>14</b>
<b>VERTILIFT BOARDROOM RANGE</b> .....	<b>15</b>
<b>ARCHITILT DRAFTING RANGE</b> .....	<b>16</b>
<b>VERTILIFT SINGLE MOTOR RANGE</b> .....	<b>17</b>
<b>VERTILIFT PRO RANGE</b> .....	<b>18</b>
<b>VERTILIFT PARTS</b> .....	<b>19</b>
<b>DESK ACCESSORIES</b> .....	<b>20</b>
<b>TABLE BASE RANGE</b> .....	<b>22</b>
<b>DYNAMIC MONITOR ARM RANGE</b> .....	<b>24</b>
<b>FIXED POST MONITOR ARM RANGE</b> .....	<b>26</b>
<b>ACOUSTIC SCREEN RANGE</b> .....	<b>28</b>
<b>SCREEN BRACKET RANGE</b> .....	<b>31</b>
<b>MOBILE PEDESTAL RANGE</b> .....	<b>32</b>
<b>GT CHAIR RANGE</b> .....	<b>34</b>
<b>R8 CHAIR RANGE</b> .....	<b>36</b>
<b>VESPA CHAIR RANGE</b> .....	<b>38</b>
<b>LOTUS CHAIR</b> .....	<b>40</b>
<b>SWIFT CHAIR</b> .....	<b>41</b>
<b>STATELINE CHAIR RANGE</b> .....	<b>42</b>
<b>BLEND BARREL OAK RANGE</b> .....	<b>46</b>
<b>BLEND WHITE RANGE</b> .....	<b>52</b>
<b>BLEND BUYING OPTIONS</b> .....	<b>58</b>
<b>BLEND WORKSTATION SIZES</b> .....	<b>61</b>
<b>STELLA PILOT RANGE</b> .....	<b>62</b>
<b>MELAMINE FURNITURE PARTS</b> .....	<b>67</b>
<b>SOFT WIRING COMPONENTS</b> .....	<b>68</b>
<b>LAYOUT PLANNER</b> .....	<b>70</b>
<b>QUOTE SUMMARY</b> .....	<b>71</b>



# VERTILIFT HEAVY DUTY RANGE



**Pictured with:**  
- V1HD2B  
- T2BO  
- VCBSB  
- VSFCT15B  
- CHAINB  
- PETFSSBB  
- BBS15CH

## 2-LEG ELECTRIC HEIGHT ADJUSTABLE FRAME

**AFRDI CERTIFIED | 180KG LOAD RATED | INTERNAL HEAVY DUTY MOTORS  
5/10 YEAR WARRANTY | SUSTAINABLE PACKAGING | QUICK ASSEMBLY SYSTEM**

### FEATURES AND SPECIFICATIONS:

- AFRDI Certified
- Lift capacity: 180kg evenly distributed
- Heavy duty 90mm x 60mm leg profile
- Height range: 600mm to 1250mm (excluding top)
- Top size compatibility (depth): 600mmD - 900mmD
- Top size compatibility (width): 1100mmW - 1800mmW (2000mmW with optional Extension Beam set)
- Foot length: 700mmL (optional 600mmL foot available - see page 10 for more info)
- Internally mounted motors within each 3-stage lift column
- Lift rate: 33mm/s
- Anti-collision with Soft-Start/Stop
- Thermal overheat protection
- Programmable Min/Max height limits
- 3-Memory handset controller with built-in USB-C outlet
- Programmable timer for 'Stand' reminder
- Child-lock feature
- 5 year warranty: electronic components (including motors)
- 10 year warranty: steel frame components
- Colours: Black, White or Silver (\* denotes colour)



**V1HD2\*: 2-LEG HEAVY DUTY FRAME**





**Pictured with:**  
 - V1HD3B  
 - T4BO  
 - VCBSB  
 - VSFCT15B  
 - CHAINB  
 - PETFSSBB  
 - BBS15CH

## 3-LEG ELECTRIC HEIGHT ADJUSTABLE FRAME

**AFRDI CERTIFIED | 220KG LOAD RATED | INTERNAL HEAVY DUTY MOTORS  
 5/10 YEAR WARRANTY | 90-180 DEGREE CAPABILITY | QUICK ASSEMBLY SYSTEM**

### FEATURES AND SPECIFICATIONS:

- AFRDI Certified
- Lift capacity: 220kg evenly distributed
- Heavy duty 90mm x 60mm leg profile
- Height range: 600mm to 1250mm (excluding top)
- Top size compatibility (depth): 600mmD - 900mmD
- Top size compatibility (width): 1200mmW - 1800mmW x 1200 x 2100 (optional extension beam adds 200mm)
- Foot length: 700mmL on main frame + 600mmL on return frame (optional 600mmL foot available - see page 10)
- Includes optional post foot for centre leg
- Internally mounted motors within each 3-stage lift column
- Lift rate: 33mm/s
- Anti-collision with Soft-Start/Stop
- Thermal overheat protection
- Programmable Min/Max height limits
- 3-Memory handset controller with built-in USB-C outlet
- Programmable timer for 'Stand' reminder
- Child-lock feature
- 5 year warranty: electronic components (including motors)
- 10 year warranty: steel frame components
- Colours: Black, White or Silver (\* denotes colour)



**V1HD3\*: 3-LEG HEAVY DUTY FRAME**

# VERTILIFT ROUND LEG RANGE



Pictured with:  
- VR2B  
- T2B0  
- VRCBSB  
- VSFCT15B  
- CHAINB  
- PETFSSBB  
- BBS15CH

## 2-LEG ELECTRIC HEIGHT ADJUSTABLE ROUND LEG FRAME

180KG LOAD RATED | INTERNAL HEAVY DUTY MOTORS  
TELESCOPIC DESIGN | 5/10 YEAR WARRANTY



VR2\*: 2-LEG ROUND LEG FRAME

### FEATURES AND SPECIFICATIONS:

- Lift capacity: 180kg evenly distributed
- Round 70mm diameter leg profile
- Height range: 600mm to 1250mm (excluding top)
- Top size compatibility (depth): 600mmD - 900mmD
- Top size compatibility (width): 1100mmW - 1800mmW (2000mmW with optional Extension Beam set)
- Foot length: 700mmL (optional 600mmL foot available - see page 10 for more info)
- Internally mounted motors within each 3-stage lift column
- Lift rate: 33mm/s
- Anti-collision with Soft-Start/Stop
- Thermal overheat protection
- Programmable Min/Max height limits
- 3-Memory handset controller with built-in USB-C outlet
- Programmable timer for 'Stand' reminder
- Child-lock feature
- 5 year warranty: electronic components (including motors)
- 10 year warranty: steel frame components
- Colours: Black, White or Silver (\* denotes colour)



Pictured with:  
 - VR3B  
 - T4BO  
 - VRCBSB  
 - VSFCT15B  
 - CHAINB  
 - PETFSSBB  
 - BBS15CH

**3-LEG ELECTRIC HEIGHT ADJUSTABLE ROUND LEG FRAME**  
**220KG LOAD RATED | INTERNAL HEAVY DUTY MOTORS | TELESCOPIC DESIGN**  
**5/10 YEAR WARRANTY | 90-180 DEGREE CAPABILITY**



**VR3\*: 3-LEG ROUND LEG FRAME**

**FEATURES AND SPECIFICATIONS:**

- Lift capacity: 220kg evenly distributed
- Round 70mm diameter leg profile
- Height range: 600mm to 1250mm (excluding top)
- Top size compatibility (depth): 600mmD - 900mmD
- Top size compatibility (width): 1200mmW - 1800mmW x 1200 x 2100 (optional extension beam adds 200mm)
- Foot length: 700mmL on main frame + 600mmL on return frame (optional 600mmL foot available - see page 10)
- Includes optional post foot for centre leg
- Internally mounted motors within each 3-stage lift column
- Lift rate: 33mm/s
- Anti-collision with Soft-Start/Stop
- Thermal overheat protection
- Programmable Min/Max height limits
- 3-Memory handset controller with built-in USB-C outlet
- Programmable timer for 'Stand' reminder
- Child-lock feature
- 5 year warranty: electronic components (including motors)
- 10 year warranty: steel frame components
- Colours: Black, White or Silver (\* denotes colour)



# VERTILIFT STATIC RANGE



Pictured with:  
- V1STAT2B  
- T2BO  
- VCBSB  
- VSFCT15B  
- PETFSSBB  
- BBS15CH

## 2-LEG FIXED HEIGHT FRAME

HEAVY DUTY CONSTRUCTION | QUICK ASSEMBLY SYSTEM  
10 YEAR WARRANTY | TELESCOPIC DESIGN



### FEATURES AND SPECIFICATIONS:

- Heavy duty 90mm x 60mm leg profile
- Height: 695mmH / 720mmH with 25mmT desk top
- Top size compatibility (depth): 600mmD - 900mmD
- Top size compatibility (width): 1100mmW - 1800mmW (2000mmW with optional Extension Beam set)
- Foot length: 700mmL (optional 600mmL foot available - see page 10 for more info)
- 10 year warranty
- Colours: Black or White (\* denotes colour)

V1STAT2\*: 2-LEG STATIC FRAME



Pictured with:  
 - V1STAT3B  
 - T4B0  
 - VCBSB  
 - VSFCT15B  
 - PETFSSBB  
 - BBS15CH

## 3-LEG FIXED HEIGHT FRAME

HEAVY DUTY CONSTRUCTION | QUICK ASSEMBLY SYSTEM | TELESCOPIC DESIGN  
 10 YEAR WARRANTY | 90-180 DEGREE CAPABILITY



### FEATURES AND SPECIFICATIONS:

- Heavy duty 90mm x 60mm leg profile
- Height: 695mmH / 720mmH with 25mmT desk top
- Top size compatibility (depth): 600mmD - 900mmD
- Top size compatibility (width): 1200mmW - 1800mmW x 1200 x 2100 (optional extension beam adds 200mm)
- Foot length: 700mmL on main frame + 600mmL on return frame (optional 600mmL foot available - see page 10)
- Includes optional post foot for centre leg
- 10 year warranty
- Colours: Black or White (\* denotes colour)

V1STAT3\*: 3-LEG STATIC FRAME

# VERTILIFT COMPONENTS

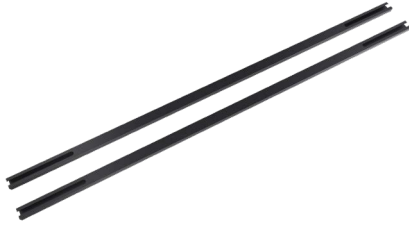

## VERTEXT\*: EXTENSION BEAM SET

- Extends standard frame by 200mm
- Set includes 2 x Extension Beams
- Available in Black, White or Silver (\* denotes colour)



## VHDF6\*: 600MM FOOT (HD)

- Converts standard HD frame (700mmL foot) to suit 600mmD desk top
- Compatible with Verlift Quick-Fit Foot installation
- Available in Black, White or Silver (\* denotes colour)



## VRF6\*: 600MM FOOT (ROUND)

- Converts standard Round Leg frame (700mmL foot) to suit 600mmD desk top
- Available in Black, White or Silver (\* denotes colour)



## VTCT\*: 1200-1800 CABLE TRAY

- Adjustable cable tray to suit 1200-1800 desk tops
- Compatible with Verlift Support Beam for Single Desk and Verlift Cross Beam for Back-to-Back application
- Provision for CMS Quad GPO (push-out section)
- 3-piece lid to suit 1200-1800 size range
- Available in Black, White or Silver (\* denotes colour)



## VSFCT15\*: 1500 CABLE TRAY

- Fixed length cable tray to suit 1500mmL desk top
- Compatible with Verlift Support Beam to suit single desk application (not suited to back to back workstation)
- Internal power and data segregation
- Compatible with Verlift Cable Chain
- Available in Black, White or Silver (\* denotes colour)



## VSFCT18\*: 1800 CABLE TRAY

- Fixed length cable tray to suit 1800mmL desk top
- Compatible with Verlift Support Beam to suit single desk application (not suited to back to back workstation)
- Internal power and data segregation
- Compatible with Verlift Cable Chain
- Available in Black, White or Silver (\* denotes colour)





### PETFSSB\*: SCREEN BRACKET

- Compatible with M&R Acoustic Workstation Screen
- Compatible with Vertilift Short Cross Beam for single desk application
- Clamp through design with locating pins
- Supplied at no cost if ordered with M&R Acoustic Screens (sold in pairs if ordered separately)
- Available in Black, White and Silver (\* denotes colour)



### VSB\*: UNIVERSAL SCREEN BRACKET

- Universal bracket compatible with non-Vertilift screens and partition systems
- Can be secured to screen using adjustable hardware or screws depending on application (hardware not included)
- Set includes 1 x Left Hand and 1 x Right Hand bracket
- Available in Black, White or Silver (\* denotes colour)



### VCBS\*: SUPPORT BEAMS (HD)

- 380mmL Support Beam designed to mount Vertilift Cable Trays and/or Acoustic Screen/Partitions to HD Frame
- Quick-fit cut out design with plastic cover plates
- Compatible with PET Screen Bracket and Universal Screen Bracket
- Available in Black, White or Silver (\* denotes colour)



### VRCBS\*: SUPPORT BEAMS (ROUND)

- 355mmL Support Beam designed to mount Vertilift Cable Trays and/or Acoustic Screen/Partitions to Round Frame
- Quick-fit cut out design with plastic cover plates
- Compatible with PET Screen Bracket and Universal Screen Bracket
- Available in Black, White or Silver (\* denotes colour)



### V120\*: 120 DEGREE BRACKET

- Converts standard 3-Leg (HD/Round/Fixed Height) frame from 90 degree corner frame to 120 degree frame
- Compatible with 3-leg frames only
- Available in Black, White or Silver (\* denotes colour)



### VPF\*: POST FOOT

- Included as standard with 3-leg frames as optional foot for centre leg
- Includes adjustable foot
- Available in Black, White or Silver (\* denotes colour)

# VERTILIFT BACK-TO-BACK RANGE



Pictured with:  
- VB2BB  
- T2BO (x2)  
- VBBCT15B  
- CHAINB (x2)  
- PETB2BSBB  
- BBS15CH

## DEDICATED HEIGHT ADJUSTABLE BACK-TO-BACK SYSTEM 180KG LOAD RATED - PER DESK | INTERNAL HEAVY DUTY MOTORS | TELESCOPIC DESIGN 5/10 YEAR WARRANTY | QUICK ASSEMBLY SYSTEM



### VB2B\*: BACK TO BACK FRAME

Includes the following:  
2 x Height Adjustable Heavy Duty Desk Frames  
1 x set of Cross Beams

### FEATURES AND SPECIFICATIONS:

- Lift capacity: 180kg evenly distributed (per frame)
- Heavy duty 90mm x 60mm leg profile
- Height range: 600mm to 1250mm (excluding top)
- Top size compatibility (depth): 600mmD - 900mmD
- Top size compatibility (width): 1100mmW - 1800mmW
- Compatible with VBBCT15 and VBBCT18 Fixed Length Cable Trays to suit 1500mmL and 1800mmL acoustic screen
- Compatible with VTCT Telescopic Cable Tray for non-standard top sizes (1200mmL to 1800mmL)
- Internally mounted motors within each 3-stage lift column
- Lift rate: 33mm/s
- Anti-collision with Soft-Start/Stop
- Thermal overheat protection
- Programmable Min/Max height limits
- 3-Memory handset controller with built-in USB-C Outlet
- Programmable timer for 'Stand' reminder
- Child-lock feature
- 5 year warranty: electronic components (including motors)
- 10 year warranty: steel frame components
- Colours: Black or White (\* denotes colour)



Pictured with:  
- VSTB2BB  
- T2BO (x2)  
- VBBCT15B  
- CHAINB (x2)  
- PETB2BSBB  
- BBS15CH

## DEDICATED FIXED HEIGHT BACK-TO-BACK SYSTEM

HEAVY DUTY CONSTRUCTION | QUICK ASSEMBLY SYSTEM  
10 YEAR WARRANTY | TELESCOPIC DESIGN



### FEATURES AND SPECIFICATIONS:

- Heavy duty 90mm x 60mm leg profile
- Height: 695mmH / 720mmH with 25mmT desk top
- Top size compatibility (depth): 600mmD - 900mmD
- Top size compatibility (width): 1100mmW - 1800mmW
- Compatible with VBBCT15 and VBBCT18 Fixed Length Cable Trays to suit 1500mmL and 1800mmL acoustic screen
- Compatible with VTCT Telescopic Cable Tray for non-standard top sizes (1200mmL to 1800mmL)
- 10 year warranty
- Colours: Black or White (\* denotes colour)

### VSTB2B\*: BACK TO BACK FRAME

Includes the following:

- 2 x Fixed Height Heavy Duty Desk Frames
- 1 x set of Cross Beams



# BACK-TO-BACK COMPONENTS



## VBBCT15\*: 1500 CABLE TRAY

- Fixed length cable tray to suit 1500mmL desk top
- Compatible with Vertilift Cross Beam to suit back to back workstation
- Internal power and data segregation
- Compatible with Vertilift Cable Chain
- Available in Black, White or Silver (\* denotes colour)



## VBBCT18\*: 1800 CABLE TRAY

- Fixed length cable tray to suit 1800mmL desk top
- Compatible with Vertilift Cross Beam to suit back to back workstation
- Internal power and data segregation
- Compatible with Vertilift Cable Chain
- Available in Black, White or Silver (\* denotes colour)



## VHDCB\*: CROSS BEAMS (HD)

- 725mmL cross-beam (support beam) designed to hold Vertilift Cable Tray and/or Acoustic Screen/Partitions for Back-to-back applications
- Included as standard with VB2B and VSTB2B, also available separately
- Quick-fit cut-out design with plastic cover plates
- Compatible with PET B2B Screen Bracket and Universal Screen Bracket
- Available in Black, White or Silver (\* denotes colour)



## PETB2BSB\*: B2B SCREEN BRACKET

- Compatible with M&R Acoustic Workstation Screen
- Compatible with Vertilift Cross Beam for back-to-back workstation application
- Clamp through design with locating pins
- Supplied at no cost if ordered with M&R Acoustic Screens (sold in pairs if ordered separately)
- Available in Black, White and Silver (\* denotes colour)



## VSB: UNIVERSAL SCREEN BRACKET

- Universal bracket compatible with non-Vertilift screens and partition systems
- Can be secured to screen using adjustable hardware or screws depending on application (hardware not included)
- Set includes 1 x Left Hand and 1 x Right Hand bracket
- Available in Black, White or Silver (\* denotes colour)



Pictured with:  
- PETFSSBB  
- BBS15LG

## WORKSTATION SCREEN PANEL

**BBS18LG: 1740mmL LIGHT GREY**

**BBS18CH: 1740mmL CHARCOAL**

**BBS15LG: 1440mmL LIGHT GREY**

**BBS15CH: 1440mmL CHARCOAL**

- 25mmT Acoustic Panel
- To suit 1800mmL desk: 1740mmL x 735mmH
- To suit 1500mmL desk: 1440mmL x 735mmH
- Finished screen height 1170mm from floor
- Colours: Charcoal or Light Grey

# VERTILIFT BOARDROOM



Pictured with:  
- VEBB  
- CHAINB  
- Custom Top

## ELECTRIC HEIGHT ADJUSTABLE MEETING TABLE FRAME

EXECUTIVE RAKED FOOT PROFILE | ROUND 3-STAGE LIFT COLUMN DESIGN  
ROUND INTERNAL HEAVY DUTY MOTORS | 5 YEAR WARRANTY

### FEATURES AND SPECIFICATIONS:

- Lift capacity: 100kg evenly distributed
- Round leg profile 70mm diameter with raked profile foot
- Height range: 700mm to 1300mm (excluding top)
- Top size compatibility (depth): 1100mmD - 1250mmD
- Top size compatibility (length): 2100mmW - 2400mmW
- Lift rate: 25mm/s
- Anti-collision with Soft-Start/Stop
- Thermal overheat protection
- Handset controller with built-in USB-A
- 5 year warranty
- Colours: Black or White (\* denotes colour)



VEB\*:MEETING TABLE FRAME

# ARCHITILT DRAFTING



Pictured with:  
- ARCHITILT15  
- TOP1575BO  
- VLAMP

## ELECTRIC HEIGHT ADJUSTABLE DRAFTING TABLE INDUSTRY-FIRST ELECTRIC HEIGHT + TILT ADJUSTABLE FRAME | PAPER RETENTION CLIPS IN-BUILT CABLE DUCTING - CMS COMPATIBLE | REVERSIBLE PAPER RETAINER



**ARCHITILT15: 1500 FRAME**

**ARCHITILT18: 1800 FRAME**

### FEATURES AND SPECIFICATIONS:

- Lift capacity 180kg evenly distributed (excl. tilt function)
- Height range 700mm - 1170mm
- Tilt range 0-45 degrees (electronic tilt mechanism)
- Frame suits tops 750 - 900mm deep
- Architilt15: fixed length frame suits tops 1200 to 1500mm
- Architilt18: fixed length frame suits tops 1650 to 1800mm
- Foot length: 700mmL (optional 600mmL foot available - see page 10 for more info)
- Internally mounted motors inside 3-stage column legs
- Handset controls both lift and tilt mechanism
- Thermal overheat protection
- Anti Collision with soft start and stop
- Heavy duty magnetic paper-stop rail (1200mmW)
- Steel paper clips to secure plans/documents
- Cable cover plate to protect wiring
- Provision to mount CMS Dual or Quad GPO
- Compatible with Desk Lamp (VLAMP)
- 5 year warranty
- Colour: Black only

# VERTILIFT SINGLE MOTOR



Pictured with:  
- VSM2B  
- T2BO

## 2-LEG SINGLE MOTOR FRAME

120KG LOAD RATED | HEAVY DUTY MOTOR | TELESCOPIC DESIGN  
5 YEAR WARRANTY | QUICK ASSEMBLY SYSTEM



VSM2\*: SINGLE MOTOR FRAME

### FEATURES AND SPECIFICATIONS:

- Lift capacity: 120kg evenly distributed
- Heavy duty 90mm x 60mm leg profile
- Height range: 700mm to 1170mm (excluding top)
- Frame range width: 1010mm - 1400mm (excluding top)
- Top size compatibility (depth): 600mmD - 800mmD
- Top size compatibility (width): 1200mmW - 1600mmW
- Foot length: 700mmL (optional 600mmL foot available - see page 10 for more info)
- Externally mounted single motor with telescopic drive bar connected to 2-stage lift columns
- Lift rate: 25mm/s
- Anti-collision with Soft-Start/Stop
- Thermal overheat protection
- 3-Memory handset controller with built-in USB-A outlet
- 5 year warranty
- Colours: Black or White (\* denotes colour)

# VERTILIFT PRO RANGE



## ELECTRIC ON-DESK RISER

**DROP SHIP PACKAGING | TOOL FREE FAST-ASSEMBLY  
COMPATIBLE WITH MONITOR ARMS | 5 YEAR WARRANTY**



### FEATURES AND SPECIFICATIONS:

- Lift capacity: 35kg evenly distributed
- Monitor platform rated to 32kg
- Keyboard tray rated to 3kg
- Height range: 145mm to 510mm
- Platform width: 880mmW x 465mmD
- Keyboard tray width: 840mmW x 255mmD
- Lift rate: 29mm/s
- Inbuilt controller with built-in USB-A outlet (new stock includes additional USB-C outlet)
- Compatible with clamp-on monitor arms (Dual or Single Monitor Arm)
- Packaged for drop-shipping with tool-free assembly (4 x finger screws to attach keyboard tray)
- 5 year warranty
- Colours: Black or White (\* denotes colour)

**VERTIPRO\*: VERTILIFT PRO**



# VERTILIFT PARTS



## CONTROL BOX

- Replacement 2-Leg Frame control box (C5E)
- Replacement 3-Leg Frame control box (C6C)
- Control boxes are backwards compatible and can be used with older model frames (internal drive motors pre VHD & VR models)
- Older frames may require a control box bracket to fix control box to underside of desk top

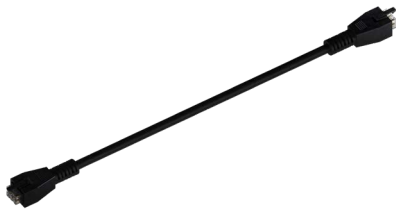

## LEG CONNECTION LEAD

- Available in 3 lengths to suit both 2-Leg and 3-Leg frames in a variety of sizes and orientations
- Leg connection leads are backwards compatible and can be used with older model frames (pre VHD & VR models)

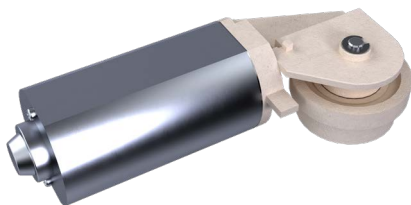

## INTERNAL DRIVE MOTOR

- Internal drive motors are backwards compatible and can be used with older model frames (pre VHD & VR models)
- It is recommended that leg connection leads are also replaced when installing new internal drive motors



H7



H12



H9



C5H

## HANDSET CONTROLLER

- Replacement handset controllers are available to suit current and previous Vertilift frame models
- Handset controllers are compatible with the current generation and can be used to match with existing frames
- Original Vertilift (H7)
- HD Range (H12)
- Round Range (H9)
- Single Motor (C5H) *includes integrated control box*



## LEG FOR HD + ROUND FRAME

- Replacement HD Leg or Round Leg
- Compatible with 2-Leg and 3-Leg frames
- Available in Black, White and Silver



## 4-LEG CONTROL SYSTEM

- 4-Leg control system used to control multiple frames for control desk, heavy usage or long-span applications
- Depending on application, some reduced handset functionality may be required due to programming limitations
- Includes cables and mounting brackets

# DESK ACCESSORIES



## VMOD\*: MODESTY PANEL

- Telescopic Modesty Panel (1100mmL to 1850mmL)
- 400mmH (290mm from floor on standard height desk)
- Mounts to the underside of top using the Vertilift Modesty Brackets (VMB) or can be screwed directly to desk top
- Universal - can be used with any workstation system
- Colour: Black or White (\* denotes colour)



## VMB\*: MODESTY PANEL BRACKET

- Compatible with Vertilift Modesty Panel
- Sold in pairs (left/right hand) includes required hardware
- Bolts directly to Modesty Panel and screws to underside of desk top
- Colour: Black or White (\* denotes colour)



## CHAIN\*: CABLE CHAIN

- Modular (clip together) plastic cable chain to provide cable segregation (ducting) from floor/cable chain to desk top
- 1200mmL; can be adjusted to required length
- Kit includes 2 x fixing plates and an optional weighted foot for single desk applications
- Fixing plates can attach directly to Vertilift Cable Tray and can be fixed to desk top using screws (provided)
- Colour: Black or White (\* denotes colour)



## VCSL\*: ZIPPER CABLE SLEEVE

- Neoprene cable sleeve with zipper to provide cable management or segregation from floor or cable tray to desk top
- Fixed length 1200mmL to suit height adjustable workstation at max height
- 25mm diameter; sufficient for several power/data cables per sleeve
- Includes fixing plate on one end to fix directly to desk top
- Provides a fast install cable management solution
- Logo printing based on MOQ of 250 units (POA)
- Colour: Black or White (\* denotes colour)



## VLAMP\*: DESK LAMP

- LED desk lamp with dual LED (2700k-6500k range)
- Adjustable 90-180 degree light position with 800mm span
- Height from desk top: 755mm+ depending on set-up
- Clamp on design (suits 18mm-70mmT top)
- Inbuilt button control and remote control supplied
- Colour: Black only



## VBH\*: BAG/HEADPHONE HOOK

- Steel hook to suit bag or headphones
- Attaches to underside of desk (screw to desk top) allowing for customisable location
- Colour: Black or White (\* denotes colour)



### VERTD\*: STEEL UTILITY DRAWER

- 480mmW x 260mmD x 50mmH
- Mounts to underside of desk top
- Non - Locking
- Metal-Bearing Runners
- 3 Year Warranty
- Colour: Black or White (\* denotes colour)



### VMAT: ANTI-FATIGUE MAT

- 990mmL x 510mmW x 18mmT
- PVC covered polyerethane structure provides support and relief when standing at height adjustable workstations
- Textured surface provides anti-slip traction
- Water resistant closed cell foam construction
- Easy to clean - Mat can be brushed, mopped or wiped
- Colour: Black only



### VCOV: MAGNETIC CABLE COVER

- Magnetic clip-on wiring cover to suit Vertilift frames
- Quickly cover under desk wiring with removable magnetic fabric upholstered cover
- Reduces assembly and installation times and allows for a refined installation
- 1000mmL to suit 1200mm-1800mm sizing
- Colour: Charcoal only



### VDWB\*: DESK TOP WHITE BOARD

- Desk top white board with inbuilt storage for pens and stationery
- Glass white board surface
- Set includes 3 x markers and 1 x eraser
- 390mmL x 180mmD x 56mmH
- Colour: Black or White (\* denotes colour)



### CA60: CABLE COVER 60MM

- Brushed stainless finish (alloy) cable access hole cover
- Suits 60mm diameter cable access hole
- Includes removable cover plate
- Includes rubber bushing for cable retention
- Logo printing based on MOQ of 250 units (POA)



### CA80: CABLE COVER 80MM

- Brushed stainless finish (alloy) cable access hole cover
- Suits 80mm diameter cable access hole
- Includes removable cover plate
- Includes rubber bushing for cable retention
- Logo printing based on MOQ of 250 units (POA)

# TABLE BASE RANGE



## STEEL DISC BASE TABLE FRAME

THREE HEIGHTS WITH MATCHING DESIGN PROFILE | SUITED TO A WIDE RANGE OF TOPS  
DURABLE POWDER COAT FINISH | 10 YEAR WARRANTY

### FEATURES AND SPECIFICATIONS:

- Matching suite of disc base table bases to suit Coffee Table, Meeting Table and Bar Table applications
- Suitable for a range of top sizes and shapes to create tables for reception areas, meeting rooms and breakout areas
- Solid 5.75mm high quality steel base with 75mm diameter post
- Coffee Table: 400mmH (excluding top) with 400mm diameter base - suits tops 450-600mm diameter
- Meeting Table: 725mmH (excluding top) with 580mm diameter base - suits tops 600-1050mm diameter
- Bar Table: 1025mmH (excluding top) with 500mm diameter base - suits tops 600mm diameter
- Simple assembly and installation
- Durable powder coat finish
- 10 year warranty
- Colours: Black or White



### **TBCW: COFFEE TABLE BASE**

- Steel disc base Coffee Table Base
- Height: 400mmH (without top)
- Top size range: 450mm - 600mm diameter
- White powder coat finish



### **TBCB: COFFEE TABLE BASE**

- Steel disc base Coffee Table Base
- Height: 400mmH (without top)
- Top size range: 450mm - 600mm diameter
- Black powder coat finish



### **TBMW: MEETING TABLE BASE**

- Steel disc base Meeting Table Base
- Height: 725mmH (without top)
- Top size range: 600mm - 1050mm diameter
- White powder coat finish



### **TBMB: MEETING TABLE BASE**

- Steel disc base Meeting Table Base
- Height: 725mmH (without top)
- Top size range: 600mm - 1050mm diameter
- Black powder coat finish



### **TBBW: BAR HEIGHT TABLE BASE**

- Steel disc base Bar Height Table Base
- Height: 1025mmH (without top)
- Top size range: 600mm diameter
- White powder coat finish



### **TBBB: BAR HEIGHT TABLE BASE**

- Steel disc base Bar Height Table Base
- Height: 1025mmH (without top)
- Top size range: 600mm diameter
- Black powder coat finish



# DYNAMIC MONITOR ARM RANGE



## DYNAMIC GAS SPRING MONITOR ARM

ROTATION CONTROL | QUICK RELEASE VESA PLATE | QUICK INSTALLATION DESIGN  
INTEGRATED CABLE MANAGEMENT | CLAMP & BOLT THROUGH KIT INCLUDED

### FEATURES AND SPECIFICATIONS:

- Dynamic tension adjustable gas spring monitor arms
- Quick-installation design: clamp installs from above with quick-detach arms
- Built-in Cable Management (colour matched)
- Screen compatibility 17" to 32"
- Weight capacity (per screen): 1 to 9kg
- Monitor rotation range: +180° / -180°
- Monitor tilt range: +45° / -45°
- Monitor swivel range: +90° / -90°
- Detachable and lockable VESA plate design (75mm x 75mm and 100mm x 100mm universal compatibility)
- Optional clamp or grommet installation kits included
- 5 year warranty
- Colours: Black or White



### LSB: BLACK SINGLE ARM

- Single adjustable monitor arm with dynamic gas spring
- Lockable quick release VESA mounting plate
- Clamp/Bolt-through kit included
- In-built cable management clips
- Fast installation design with top-side clamp attachment and removable quick-fit arm segments
- In-built rotation/swing control
- Colour: Matte Black



### LDB: BLACK DUAL ARM

- Dual adjustable monitor arm with dynamic gas spring
- Lockable quick release VESA mounting plate
- Clamp/Bolt-through kit included
- In-built cable management clips
- Fast installation design with top-side clamp attachment and removable quick-fit arm segments
- In-built rotation/swing control
- Colour: Matte Black



### LSW: WHITE SINGLE ARM

- Single adjustable monitor arm with dynamic gas spring
- Lockable quick release VESA mounting plate
- Clamp/Bolt-through kit included
- In-built cable management clips
- Fast installation design with top-side clamp attachment and removable quick-fit arm segments
- In-built rotation/swing control
- Colour: Matte White



### LDW: WHITE DUAL ARM

- Dual adjustable monitor arm with dynamic gas spring
- Lockable quick release VESA mounting plate
- Clamp/Bolt-through kit included
- In-built cable management clips
- Fast installation design with top-side clamp attachment and removable quick-fit arm segments
- In-built rotation/swing control
- Colour: Matte White

# FIXED POST MONITOR ARM RANGE

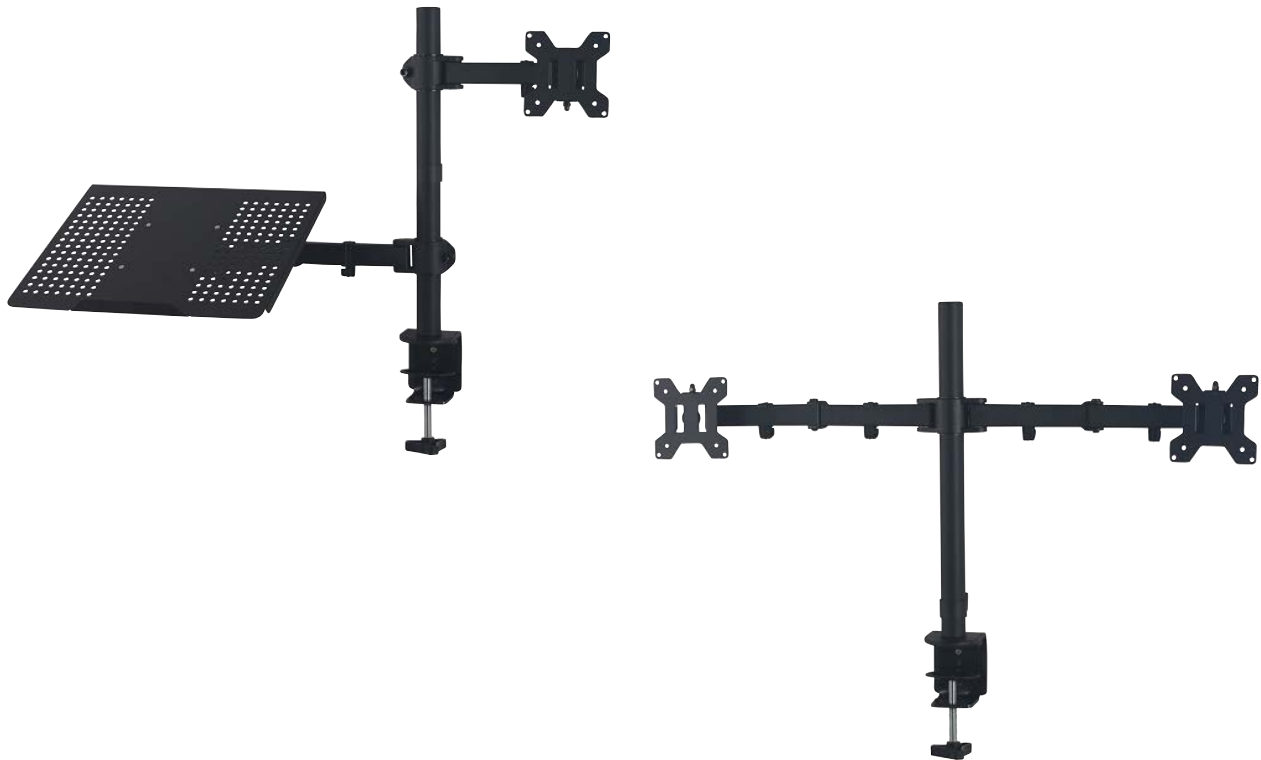

## FIXED POST ADJUSTABLE MONITOR ARM

**QUICK RELEASE VESA PLATE | CLIP-ON CABLE MANAGEMENT | ADJUSTABLE HEIGHT  
CLAMP & BOLT THROUGH KIT INCLUDED | ADJUSTABLE TILT & ROTATION**

### FEATURES AND SPECIFICATIONS:

- Fixed post adjustable monitor arms + laptop tray combination
- Clip-on cable management
- Screen compatibility 13" to 27"
- Weight capacity (per screen): 1 to 10kg
- Weight capacity (laptop tray): 5kg
- Monitor rotation range: +180° / -180°
- Monitor tilt range: +45° / -45°
- Monitor swivel range: +90° / -90°
- Laptop tray size: 355mmW x 300mmD
- Vented laptop tray to allow for cooling/airflow
- Detachable quick-fit VESA plate design (75mm x 75mm and 100mm x 100mm universal compatibility)
- Optional clamp or grommet installation kits included (all tools included)
- 10 year warranty
- Colour: Black only



### M1B: SINGLE ARM

- Single adjustable monitor arm (fixed post)
- Quick release VESA mounting plate
- Clamp/Bolt-through kit included
- Cable management clips with tool storage



### M2B: DUAL ARM

- Dual adjustable monitor arm (fixed post)
- Quick release VESA mounting plate
- Clamp/Bolt-through kit included
- Cable management clips with tool storage



### MLTB: LAPTOP ARM

- Adjustable laptop tray arm (fixed post)
- Quick release VESA mounting plate
- Clamp/Bolt-through kit included
- Cable management clips with tool storage



### M1LTB: SINGLE + LAPTOP ARM

- Adjustable laptop tray arm + monitor arm (fixed post)
- Quick release VESA mounting plate
- Clamp/Bolt-through kit included
- Cable management clips with tool storage

# ACOUSTIC SCREEN RANGE



## ACOUSTIC SCREENS

**EXCELLENT ACOUSTIC PERFORMANCE | INTEGRATES WITH VERTILIFT AND BLEND RANGES  
PINNABLE SURFACE | DURABLE & LOW MAINTENANCE FINISH | SUSTAINABLE PRODUCTION**

### A SUSTAINABLE SOLUTION:

Manufactured from PET (Recycled Post-Consumer Polyester) which comes from plastic waste collected in the environment, mainly from oceans and landfill sites.

In addition to the excellent acoustic properties, the production of these Acoustic Screens contributes to the global effort to remove and re-purpose plastic waste from the environment.

The Acoustic Screen range presents an opportunity to work towards a sustainable future.

### FEATURES AND SPECIFICATIONS:

- 18mmT nominal thickness for Wrap, Front Mount and Desk Mount screen panels
- 25mmT nominal thickness for Back-to-Back and Slip-on Divider screen panels
- Pinnable textured surface
- Radius profile corners (30mm radius)
- Screens and Brackets designed to integrate seamlessly with the Vertilift Range and Blend Range
- Brackets included in price (also sold separately)
- 3 year warranty
- Colours: Charcoal or Light Grey
- Bracket colours: Black or White



## DESK MOUNT / MODESTY SCREEN PANEL

- 18mmT Acoustic Panel
- Suits desk mount or modesty mount application
- To suit 1800mmL desk: 1760mmL x 380mmH
- To suit 1500mmL desk: 1460mmL x 380mmH
- To suit 1200mmL desk: 1160mmL x 380mmH
- Finished screen height 400mm from desk top (including brackets - 20mm)
- Colours: Charcoal or Light Grey

### Bracket options:

- One set of brackets included with each screen
- Back-to-back: DMSBB\*
- Single desk: DMSBS\*
- Modesty mount: DMM\*
- Bracket colours: Black or White (\* denotes colour)



**DMS17LG:** 1760mmL LIGHT GREY

**DMS17CH:** 1760mmL CHARCOAL

**DMS14LG:** 1460mmL LIGHT GREY

**DMS14CH:** 1460mmL CHARCOAL

**DMS11LG:** 1160mmL LIGHT GREY

**DMS11CH:** 1160mmL CHARCOAL

## FRONT MOUNT SCREEN PANEL

- 18mmT Acoustic Panel
- Combined desk mount screen and partial modesty
- To suit 1800mmL desk: 1760mmL x 585mmH
- To suit 1500mmL desk: 1460mmL x 585mmH
- To suit 1200mmL desk: 1160mmL x 585mmH
- Finished screen height 400mm from desk top and 160mm below desk top
- Colours: Charcoal or Light Grey

### Bracket options:

- One set of brackets included with each screen
- Compatible only with M&R Brackets (MMSB\*)
- Bracket colours: Black or White (\* denotes colour)



**MMS17LG:** 1760mmL LIGHT GREY

**MMS17CH:** 1760mmL CHARCOAL

**MMS14LG:** 1460mmL LIGHT GREY

**MMS14CH:** 1460mmL CHARCOAL

**MMS11LG:** 1160mmL LIGHT GREY

**MMS11CH:** 1160mmL CHARCOAL

## WRAP SCREEN PANEL

- 18mmT Acoustic Panel
- Provides desk mount screen and partial modesty
- To suit 1800mmL desk: 2409mmL x 585mmH
- To suit 1500mmL desk: 2109mmL x 585mmH
- Finished screen height 400mm from desk top and 160mm below desk top
- Screen returns 280mm on each side
- Colours: Charcoal or Light Grey

### Bracket options:

- Two sets of brackets included with each screen
- Compatible only with M&R Brackets (MMSB\*)
- Bracket colours: Black or White (\* denotes colour)



**WS17LG:** 1800mmL LIGHT GREY

**WS17CH:** 1800mmL CHARCOAL

**WS14LG:** 1500mmL LIGHT GREY

**WS14CH:** 1500mmL CHARCOAL

# ACOUSTIC SCREEN RANGE

## SLIDE-ON DIVIDER SCREEN PANEL

- 25mm Acoustic Panel
- Suits 750mmD desk tops only
- No brackets required; designed to slide over 25mmT desk top
- Easily removed / reinstalled for collaboration spaces
- Finished screen height 400mm from desk top
- Colours: Charcoal or Light Grey



**DSLГ:** LIGHT GREY

**DSCH:** CHARCOAL

## WORKSTATION SCREEN PANEL

- 25mm Acoustic Panel
- Designed to integrate with Vertilift Desk Range (free standing or back-to-back configuration)
- To suit 1800mmL desk: 1740mmL x 735mmH
- To suit 1500mmL desk: 1440mmL x 735mmH
- Finished screen height 1170mm from floor
- Radius corners on top only (square profile base)
- Colours: Charcoal or Light Grey

### Bracket options:

- One set of brackets included with each screen (also available for purchase separately)
- Compatible only with M&R Brackets and Vertilift Range, codes (PETB2BSB\* or PETFSSB\*)
- Bracket colours: Black, White or Silver (\* denotes colour)



Pictured with:  
- PETFSSBB  
- BBS15LG

**BBS18LG:** 1740mmL LIGHT GREY

**BBS18CH:** 1740mmL CHARCOAL

**BBS15LG:** 1440mmL LIGHT GREY

**BBS15CH:** 1440mmL CHARCOAL

# SCREEN BRACKET RANGE



## DMSBS\*: DESK MOUNT BRACKET

- Compatible with M&R Acoustic Desk Mount screen
- Clamps over edge of desk + fixes to desk from underside (fixing hardware not included)
- Supplied at no cost if ordered with M&R Acoustic Screens (sold in pairs if ordered separately)
- Available in Black or White (\*denotes colour)



## DMSBB\*: B2B DESK MOUNT BRACKET

- Compatible with M&R Acoustic Desk Mount screen
- Clamps over edge of desk + fixes between two desk tops (fixing hardware not included)
- Supplied at no cost if ordered with M&R Acoustic Screens (sold in pairs if ordered separately)
- Available in Black or White (\*denotes colour)



## DMM\*: MODESTY MOUNT BRACKET

- Compatible with M&R Acoustic Desk Mount screen
- Fitted to underside of desk (fixing hardware not included)
- Supplied at no cost if ordered with M&R Acoustic Screens (sold in pairs if ordered separately)
- Available in Black or White (\*denotes colour)



## MMSB\*: FRONT/WRAP BRACKET

- Compatible with M&R PET Front Mount and Wrap Screen only
- Clamp through design with locating pins
- Supplied at no cost if ordered with M&R Acoustic Screens (sold in pairs if ordered separately)
- Available in Black or White (\*denotes colour)



## PETB2BSB\*: BACK-TO-BACK BRACKET

- Compatible with M&R Acoustic Workstation Screen
- Compatible with Vertilift Cross Beam for back-to-back workstation application
- Clamp through design with locating pins
- Supplied at no cost if ordered with M&R Acoustic Screens (sold in pairs if ordered separately)
- Available in Black, White or Silver (\*denotes colour)



## PETFSSB\*: SINGLE DESK BRACKET

- Compatible with M&R Acoustic Workstation Screen
- Compatible with Vertilift Short Cross Beam for single desk application
- Clamp through design with locating pins
- Supplied at no cost if ordered with M&R Acoustic Screens (sold in pairs if ordered separately)
- Available in Black, White or Silver (\*denotes colour)

# MOBILE PEDESTAL RANGE



## STEEL MOBILE PEDESTALS

**BIFMA CERTIFIED | DURABLE & LOW MAINTENANCE FINISH | SUSTAINABLE PACKAGING  
ANTI-TILT CASTOR | PENCIL TRAY INCLUDED | 10 YEAR WARRANTY**

### A SUSTAINABLE SOLUTION

Mobile Pedestals are sustainably packaged (without plastic or polystyrene) to minimise waste and reduce the overall environmental impact.

Our packaging has been engineered to balance damage prevention and sustainability, and presents an opportunity to work towards a sustainable future.

### BIFMA CERTIFIED

Mobile Pedestals are BIFMA certified which qualifies for Government, Defence, Education and Specialised Application Tenders and Projects.

### FEATURES AND SPECIFICATIONS:

- Stationery tray included in top drawer
- Locking mechanism (2 foldable keys)
- Locking castors (front castor wheels)
- Anti-tilt castor fixed to filing drawer
- Heavy duty runners fitted to each drawer
- 0.6mm steel thickness (carcass)
- 0.7mm steel thickness (top/drawer fronts)
- 10 year warranty
- Colours: Black or White



**MR300B: SLIMLINE PEDESTAL**

- 300mmW x 520mmD x 600mmH
- 10 year warranty
- BIFMA Certified
- Black powder-coat finish



**MR390B: STANDARD PEDESTAL**

- 390mmW x 520mmD x 600mmH
- 10 year warranty
- BIFMA Certified
- Black powder-coat finish



**MR300W: SLIMLINE PEDESTAL**

- 300mmW x 520mmD x 600mmH
- 10 year warranty
- BIFMA Certified
- White powder-coat finish



**MR390W: STANDARD PEDESTAL**

- 390mmW x 520mmD x 600mmH
- 10 year warranty
- BIFMA Certified
- White powder-coat finish



# GT CHAIR



## GT CHAIR

**BIFMA CERTIFIED | 135KG RATED SYNCHRO-MECHANISM | KOREAN WINTEX COMFORT MESH  
7 YEAR WARRANTY | CABLE OPERATED MECHANISM**



### FEATURES AND SPECIFICATIONS:

- True Synchro-Mechanism (auto balancing); tension adjustment and 3-point locking
- Cable mechanism with accented levers for adjustment
- BIFMA Rated (135kg weight rating)
- WINTEX high-elasticity breathable comfort mesh back and seat
- Adjustable lumbar support; 9 incremental adjustment options
- Height adjustable mesh headrest (optional); 6 incremental adjustment options
- 3D adjustable armrest (optional)
- Comfort padded front edge built into mesh seat
- Inbuilt seat slide function; 50mm depth adjustment
- 360mm nylon 5-star base
- 60mm colour matched castor wheels
- Class 3 85/60 Gas Stem
- 7 year warranty

Colour options:

- Black shell with Charcoal mesh
- White shell with Charcoal mesh



**GTB: BLACK GT CHAIR**

- Arms/Headrest can be added as required
- Black shell with Charcoal mesh



**GTW: WHITE GT CHAIR**

- Arms/Headrest can be added as required
- White shell with Charcoal mesh



**GTBHREST: BLACK GT HEADREST**

- Headrest can be added to chair at any time
- Black shell with Charcoal mesh



**GTWHREST: WHITE GT HEADREST**

- Headrest can be added to chair at any time
- White shell with Charcoal mesh



**GTBARMS: BLACK GT ARMS**

- Arms can be added to chair at any time
- 3D adjustable armrest
- Black with charcoal pad



**GTWARMS: WHITE GT ARMS**

- Arms can be added to chair at any time
- 3D adjustable armrest
- White with charcoal pad

# R8 CHAIR



## R8 CHAIR

**BIFMA CERTIFIED | 135KG RATED SYNCHRO-MECHANISM | KOREAN WINTEX COMFORT MESH  
7 YEAR WARRANTY | COMFORT MOULDED FOAM SEAT | PREMIUM COMFORT**



### FEATURES AND SPECIFICATIONS:

- True Synchro-Mechanism (auto balancing); tension adjustment and 3-point locking
- BIFMA Rated (135kg weight rating)
- R8: WINTEX high-elasticity breathable comfort mesh back and black upholstered seat
- R8-CH: WINTEX elastic charcoal fabric-mesh comfort back with charcoal upholstered seat
- Adjustable lumbar support; 9 incremental adjustment options
- Height adjustable mesh headrest (optional); 6 incremental adjustment options
- 3D adjustable armrest (optional)
- Inbuilt seat slide function; 50mm depth adjustment
- 350mm nylon 5-star base
- 60mm colour matched castor wheels
- Class 4 100/60 Gas Stem
- 7 year warranty

#### Colour options:

- Black mesh back with black upholstered seat
- Charcoal fabric mesh back with charcoal upholstered seat



### **R8: BLACK CHAIR ONLY**

- Arms/Headrest can be added as required
- Black mesh back with black upholstered seat



### **R8-CH: CHARCOAL CHAIR ONLY**

- Arms/Headrest can be added as required
- Charcoal fabric mesh back with Charcoal upholstered seat



### **R8HREST: BLACK HEADREST**

- Headrest can be added to chair at any time
- Black shell with black mesh



### **R8HREST-CH: CHARCOAL HEADREST**

- Headrest can be added to chair at any time
- Black shell with charcoal fabric mesh



### **R8ARMS: ADJUSTABLE ARMS**

- Compatible with R8 or R8-CH chairs
- Arms can be added to chair at any time
- 3D adjustable armrest
- Black with black pad

# VESPA CHAIR



## VESPA TASK CHAIR

**BIFMA CERTIFIED | 135KG RATED SYNCHRO-MECHANISM | KOREAN WINTEX COMFORT MESH  
7 YEAR WARRANTY | COMFORT MOULDED FOAM SEAT | SEAT SLIDE**

### FEATURES AND SPECIFICATIONS:

- True Synchro-Mechanism (auto balancing); tension adjustment and 3-point locking
- BIFMA Rated (135kg weight rating)
- WINTEX high-elasticity breathable comfort mesh back and upholstered seat
- Height adjustable mesh headrest (optional)
- 3D adjustable armrest
- Inbuilt seat slide function; 50mm depth adjustment
- 350mm nylon 5-star base
- 60mm castor wheels
- Class 4 100/60 Gas Stem
- 7 year warranty

Colour options: Black, Sand, Light Grey, Teal or Coral





### VESPA-B: CHAIR + ARMS

- Sold as chair with adjustable arms included
- Matching headrest can be added as required
- Colour: Black



### VHR-B: HEADREST

- Sold as headrest only
- Can be retrofitted to VESPA-B Chair
- Colour: Black



### VESPA-S: CHAIR + ARMS

- Sold as chair with adjustable arms included
- Matching headrest can be added as required
- Colour: Sand



### VHR-S: HEADREST

- Can be retrofitted to VESPA-S Chair
- Colour: Sand



### VESPA-LG: CHAIR + ARMS

- Sold as chair with adjustable arms included
- Matching headrest can be added as required
- Colour: Light Grey



### VHR-LG: HEADREST

- Can be retrofitted to VESPA-LG Chair
- Colour: Light Grey



### VESPA-T: CHAIR + ARMS

- Sold as chair with adjustable arms included
- Matching headrest can be added as required
- Colour: Teal



### VHR-T: HEADREST

- Can be retrofitted to VESPA-T Chair
- Colour: Teal



### VESPA-C: CHAIR + ARMS

- Sold as chair with adjustable arms included
- Matching headrest can be added as required
- Colour: Coral



### VHR-C: HEADREST

- Can be retrofitted to VESPA-C Chair
- Colour: Coral



# LOTUS CHAIR



## LOTUS CHAIR

**BIFMA CERTIFIED | 135KG RATED | WINTEX COMFORT MESH | 5 YEAR WARRANTY**



**LOTUS: TASK CHAIR**

### FEATURES AND SPECIFICATIONS:

- Back tilting mechanism with tension adjustment and single point locking
- BIFMA Rated (135kg weight rating)
- WINTEX high-elasticity breathable comfort mesh back and black upholstered seat
- Fixed arm rests (included)
- 330mm nylon 5-star base
- 60mm colour matched castor wheels
- Class 3 120/60 Gas Stem
- 5 year warranty



# SWIFT CHAIR



## SWIFT MEETING CHAIR

**MOLDED FOAM UPHOLSTERED SEAT | INTEGRATED MOULDED PLASTIC SEAT PAN  
7 YEAR WARRANTY | DUAL LAYER MESH BACK | MOLDED PLASTIC ARM PADS**



### FEATURES AND SPECIFICATIONS:

- Molded foam upholstered seat with mesh back
- Integrated molded plastic seat under-pan
- Double-layer mesh cloth
- Integrated armrest with plastic pad
- Matte Black Powder-coating
- Stackable structure design
- Soft wear-resistant foot
- 120kg weight rating (BIFMA)
- 7 year warranty

**SWIFT: MEETING CHAIR**

# STATELINE CHAIR RANGE



## ERGO: ERGOFORM

- Upholstered in Black fabric
- Adjustable seat height
- Adjustable ratchet back height
- Adjustable back and seat angle
- Adjustable seat depth, seat slide
- Moulded comfort foam
- Non-marking castors with black nylon base
- 7 Year warranty
- AFRDI weight rated 160kg (AFRDI Level 6)



## ERGOAIR: ERGOFORM AIR

- Upholstered in Black fabric
- Pneumatic lumbar air pump
- Adjustable seat height
- Adjustable ratchet back height
- Adjustable back and seat angle
- Adjustable seat depth, seat slide
- Moulded comfort foam
- Non-marking castors with black nylon base
- 7 Year warranty
- AFRDI weight rated 160kg (AFRDI Level 6)



## END: ENDEAVOUR 103

- Upholstered in black fabric
- Pronounced lumbar support
- Adjustable back & seat height
- Adjustable back and seat angle
- Adjustable seat depth, seat slide
- Moulded comfort foam
- Non-marking castors with black nylon base
- 7 Year warranty
- AFRDI weight rated 160kg (AFRDI Level 6)



#### **MADRID: MADRID MEDIUM BACK**

- Upholstered seat in Black fabric
- Black mesh back
- Adjustable seat height
- Adjustable ratchet back height
- Adjustable back and seat angle
- Adjustable seat depth, seat slide
- Moulded comfort foam
- Non-marking castors with black nylon base
- 7 Year warranty
- AFRDI weight rated 160kg (AFRDI Level 6)



#### **MADRIDHBB: MADRID HIGH BACK**

- Upholstered seat in Black fabric
- Black mesh back
- Adjustable seat height
- Adjustable ratchet back height
- Adjustable back and seat angle
- Adjustable seat depth, seat slide
- Moulded comfort foam
- Adjustable lumbar support
- Non-marking castors with black nylon base
- 7 Year warranty
- AFRDI weight rated 110kg (AFRDI Level 6)



#### **MIRAE: MIRAE MEDIUM BACK**

- Upholstered seat in Black fabric
- Black mesh back
- Adjustable seat height
- Adjustable ratchet back height
- Adjustable back and seat angle
- Adjustable seat depth, seat slide
- Moulded comfort foam
- Non-marking castors with black nylon base
- 7 Year warranty
- AFRDI weight rated 160kg (AFRDI Level 6)

# STATELINE CHAIR RANGE



## MIRAEHBB: MIRA HIGH BACK

- Upholstered seat in Black fabric
- Black mesh high back (fixed height)
- Adjustable seat height
- Adjustable back and seat angle
- Adjustable seat depth, seat slide
- Moulded comfort foam
- Non-marking castors with black nylon base
- 7 Year warranty
- AFRDI weight rated 160kg (AFRDI Level 6)



## MERIDAHBB: MERIDA HIGH BACK

- Upholstered seat in Black fabric
- Black mesh high back
- Adjustable seat height
- Adjustable ratchet back height
- Adjustable back and seat angle
- Adjustable seat depth, seat slide
- Moulded comfort foam
- Non-marking castors with black nylon base
- 7 Year warranty
- AFRDI weight rated 160kg (AFRDI Level 6)



## SEVHBB: SEVILLE HIGH BACK

- Upholstered seat in Black fabric
- Black mesh high back
- Ratchet adjustable back height
- Adjustable seat height
- Adjustable back and seat angle
- Adjustable seat depth, seat slide
- Moulded comfort foam + lumbar support
- Non-marking castors with black nylon base
- 7 Year warranty
- AFRDI weight rated 160kg (AFRDI Level 6)



### **SPENCER: MEETING CHAIR**

- Upholstered seat in black fabric
- Black breathable mesh back
- Powder coated silver sled frame
- Includes linking feet
- Comfort foam
- Stacks 4 high assembled
- Weight rated to 110kg
- BIFMA approved
- 3 Year Warranty



### **SLARMS: ARM KIT**

- Arm rest kit includes 2 x adjustable arms with steel mounting brackets
- Compatible with Stateline Chairs (can be retrofitted if not ordered with chair)
- PU comfort-shaped arm-pad
- Colour: Black



### **HRMESH: MESH HEAD REST**

- Adjustable mesh head rest (height and tilt)
- Compatible with High-Back Stateline Chairs only (can be retrofitted if not ordered with chair)
- Colour: Black



### **SLDKIT: DRAFTING KIT**

Optional drafting kit includes the following components:

- Adjustable foot ring (black)
- Tall gas stem (black)
- Plastic gas stem protector (black)
- Suitable for Medium Back Stateline Chairs (not recommended for use with High Back Chairs)
- Excludes nylon base and castors

# BLEND BARREL OAK RANGE



**DESIGNED TO CATER TO BOTH COMMERCIAL AND HOME OFFICE ENVIRONMENTS, THIS RANGE OFFERS A SEAMLESS COMBINATION OF AFFORDABILITY AND VERSATILITY. WITH A COMPREHENSIVE SELECTION OF DESKS, WORKSTATIONS, AND STORAGE OPTIONS, THE BLEND 'BARREL OAK' RANGE PROVIDES A COHESIVE AND COMPLIMENTARY SET OF SOLUTIONS FOR YOUR WORKSPACE NEEDS.**

## **FEATURES AND SPECIFICATIONS:**

- 25mm tops over 25mm end panels for corner workstation and returns (18mm modesty)
- 25 mm top/base/shelves over 18mm back/sides/doors on credenzas, bookcases and hutches
- Matte-black hardware (handles, locks and cable access covers)
- CL2 Locks (2-keys) for mobile pedestal, credenzas and cabinets
- Soft close 3D adjustable cabinet hinges included with Stationery Cabinet and Utility Cabinet
- Adjustable screw in leveling feet on all desks, corner workstations and returns (D Nut)
- 25mm adjustable wind-up leveling feet on all storage items
- 60mm cable access holes with black covers for desking, corner workstations and returns
- 80mm cable access holes for corner desk tops
- E1 Melamine Particle Board
- 2mm matching ABS Edging on exposed face edges
- 1mm matching ABS edging on exposed bottom edges (modesty, back, side and end panels)
- 40mm overhang on rear edge/sides of desks, corner workstation and returns to accommodate commercial skirting
- Colour: Natural Oak (blends seamlessly with locally manufactured Natural Oak joinery)
- Compatible with Blend White Range (refer to page 58 for information on Blend Range buying options)
- Warranty: 5 year warranty

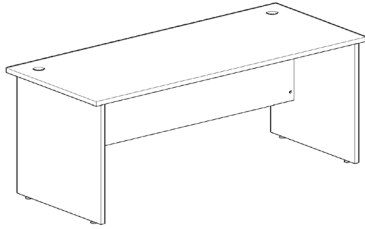

**B036: 1800 x 750 DESK**

- 1800mmL x 750mmD x 720mmH
- 25mm Top/End Panels and 18mm Modesty (3/4)
- 720mm desk height with adjustable feet
- 2 x 60mm cable access holes with black covers
- 40mm overhang (sides/rear) for commercial skirting

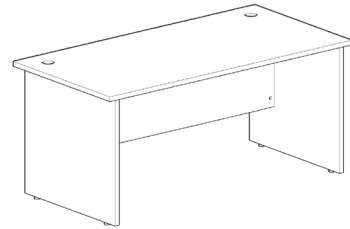

**B02: 1500 x 750 DESK**

- 1500mmL x 750mmD x 720mmH
- 25mm Top/End Panels and 18mm Modesty (3/4)
- 720mm desk height with adjustable feet
- 2 x 60mm cable access holes with black covers
- 40mm overhang (sides/rear) for commercial skirting

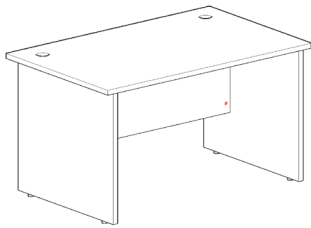

**B03: 1200 x 750 DESK**

- 1200mmL x 750mmD x 720mmH
- 25mm Top/End Panels and 18mm Modesty (3/4)
- 720mm desk height with adjustable feet
- 2 x 60mm cable access holes with black covers
- 40mm overhang (sides/rear) for commercial skirting

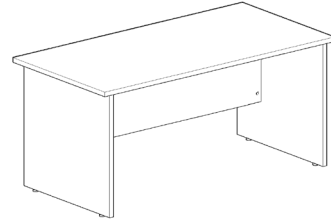

**B04: 1200 x 600 DESK**

- 1200mmL x 600mmD x 720mmH
- 25mm Top/End Panels and 18mm Modesty (3/4)
- 720mm desk height with adjustable feet
- No cable access holes
- 40mm overhang (sides/rear) for commercial skirting

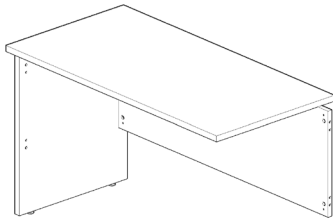

**B05: 1200 x 600 RETURN**

- 1200mmL x 600mmD x 720mmH
- 25mm Top/End Panels and 18mm Modesty (3/4)
- 720mm desk height with adjustable feet
- 40mm overhang (sides/rear) for commercial skirting
- Compatible with Desk or Corner Unit (600mmD - BO126)
- Reversible; Left-hand or Right-hand assembly

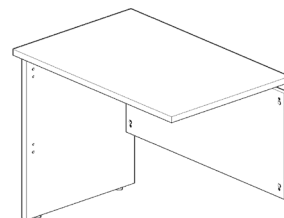

**B06: 900 x 600 RETURN**

- 900mmL x 600mmD x 720mmH
- 25mm Top/End Panels and 18mm Modesty (3/4)
- 720mm desk height with adjustable feet
- 40mm overhang (sides/rear) for commercial skirting
- Compatible with Desk or Corner Unit (600mmD - BO126)
- Reversible; Left-hand or Right-hand assembly

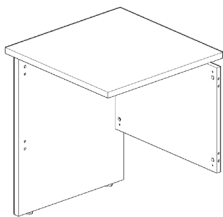

**B08: 600 x 600 RETURN**

- 600mmL x 600mmD x 720mmH
- 25mm Top/End Panels and 18mm Modesty (3/4)
- 720mm desk height with adjustable feet
- 40mm overhang (sides/rear) for commercial skirting
- Compatible with Desk or Corner Unit (600mmD - BO126)
- Reversible; Left-hand or Right-hand assembly

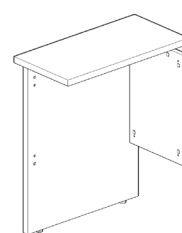

**B09: 300 x 600 RETURN**

- 300mmL x 600mmD x 720mmH
- 25mm Top/End Panels and 18mm Modesty (3/4)
- 720mm desk height with adjustable feet
- 40mm overhang (sides/rear) for commercial skirting
- Compatible with Desk or Corner Unit (600mmD - BO126)
- Reversible; Left-hand or Right-hand assembly



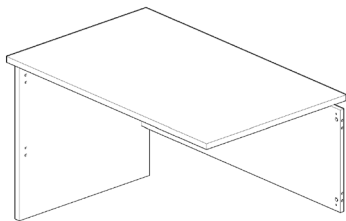

**B0575: 1200 x 750 RETURN**

- 1200mmL x 750mmD x 720mmH
- 25mm Top/End Panels and 18mm Modesty (3/4)
- 720mm desk height with adjustable feet
- 40mm overhang (sides/rear) for commercial skirting
- Compatible with Desk or Corner Unit (750mmD - B01275)
- Reversible; Left-hand or Right-hand assembly

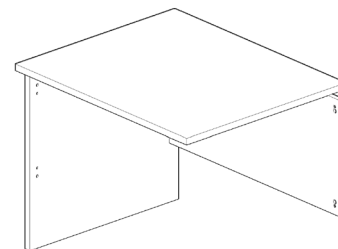

**B0675: 900 x 750 RETURN**

- 900mmL x 750mmD x 720mmH
- 25mm Top/End Panels and 18mm Modesty (3/4)
- 720mm desk height with adjustable feet
- 40mm overhang (sides/rear) for commercial skirting
- Compatible with Desk or Corner Unit (750mmD - B01275)
- Reversible; Left-hand or Right-hand assembly

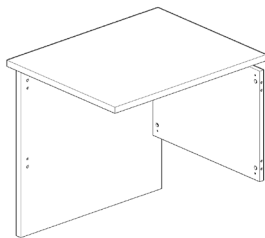

**B0875: 600 x 750 RETURN**

- 600mmL x 750mmD x 720mmH
- 25mm Top/End Panels and 18mm Modesty (3/4)
- 720mm desk height with adjustable feet
- 40mm overhang (sides/rear) for commercial skirting
- Compatible with Desk or Corner Unit (750mmD - B01275)
- Reversible; Left-hand or Right-hand assembly

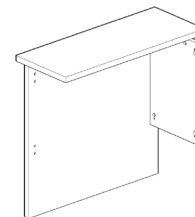

**B0975: 300 x 750 RETURN**

- 300mmL x 750mmD x 720mmH
- 25mm Top/End Panels and 18mm Modesty (3/4)
- 720mm desk height with adjustable feet
- 40mm overhang (sides/rear) for commercial skirting
- Compatible with Desk or Corner Unit (750mmD - B01275)
- Reversible; Left-hand or Right-hand assembly

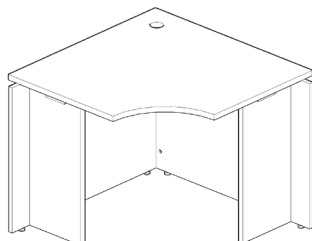

**B0126: 600D CORNER UNIT**

- 900mmL x 900mmW x 600mmD x 720mmH
- 25mm Top/End Panels and 18mm Modesty (full)
- 720mm desk height with adjustable feet
- 40mm overhang (sides/rear) for commercial skirting
- Compatible with 600mmD Returns
- Cable access holes in Top, Modesty and Legs

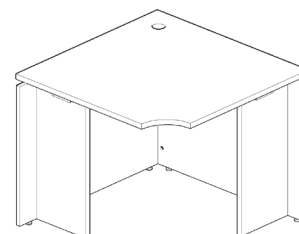

**B01275: 750D CORNER UNIT**

- 900mmL x 900mmW x 750mmD x 720mmH
- 25mm Top/End Panels and 18mm Modesty (full)
- 720mm desk height with adjustable feet
- 40mm overhang (sides/rear) for commercial skirting
- Compatible with 750mmD Returns
- Cable access holes in Top, Modesty and Legs



**B014: MOBILE PEDESTAL 2+1**

- 675mmH x 405mmW x 470mmD
- 25mm Top and Base / 18mm Carcass and Drawer Fronts
- Factory assembled - castors and handles to be fitted
- Black handles and lock (Black CL2 Lock - 2 Keys)
- Anti-tilt castor fitted to base of file drawer
- 2-locking castors + 2 free spinning castors



**B019: 1800 x 900 BOOKCASE**

- 1800mmH x 900mmW x 320mmD
- 25mm Top/Shelves/Base and 18mm Back/Sides
- 1 x Fixed Shelf + 3 x Adjustable Shelves (spacing allows for full size binder folders)
- Internal shelf measurement: 860mmW x 292mmD
- Adjustable 25mm nylon leveling feet



**B043: 900 x 900 BOOKCASE**

- 900mmH x 900mmW x 320mmD
- 25mm Top/Shelves/Base and 18mm Back/Sides
- 2 x Adjustable Shelves (allows for full size binder folders)
- Internal shelf measurement: 860mmW x 292mmD
- Adjustable 25mm nylon leveling feet



**B020: STATIONERY CABINET**

- 1800mmH x 900mmW x 450mmD
- 25mm Top/Shelves/Base and 18mm Back/Doors/Sides
- 1 x Fixed Shelf + 3 x Adjustable Shelves
- Soft-close 3D adjustable cabinet hinges
- Black handles and lock (CL2 lock + 2 keys)
- Adjustable 25mm nylon leveling feet



**B022: UTILITY CABINET**

- 900mmH x 900mmW x 450mmD
- 25mm Top/Shelves/Base and 18mm Back/Doors/Sides
- 2 x Adjustable Shelves
- Soft-close 3D adjustable cabinet hinges
- Black handles and lock (CL2 lock + 2 keys)
- Adjustable 25mm nylon leveling feet

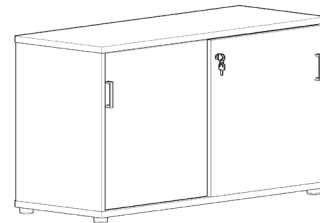

**B023: 1200 CREDENZA**

- 1200mmW x 720mmH x 450mmD
- 25mm Top/Shelves/Base and 18mm Back/Sides/Doors
- 2 x Adjustable Shelves
- Internal shelf measurement: 570mmW x 353mmD
- Black handles and lock (CL2 lock - 2 keys)
- Adjustable 25mm nylon leveling feet

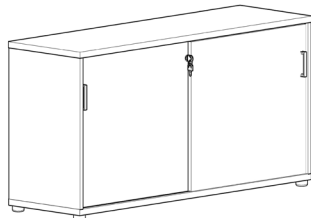

**B024: 1500 CREDENZA**

- 1500mmW x 720mmH x 450mmD
- 25mm Top/Shelves/Base and 18mm Back/Sides/Doors
- 2 x Adjustable Shelves
- Internal shelf measurement: 720mmW x 353mmD
- Black handles and lock (CL2 lock - 2 keys)
- Adjustable 25mm nylon leveling feet

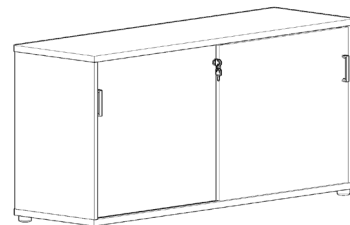

**B025: 1800 CREDENZA**

- 1800mmW x 720mmH x 450mmD
- 25mm Top/Shelves/Base and 18mm Back/Sides/Doors
- 2 x Adjustable Shelves
- Internal shelf measurement: 870mmW x 353mmD
- Black handles and lock (CL2 lock - 2 keys)
- Adjustable 25mm nylon leveling feet

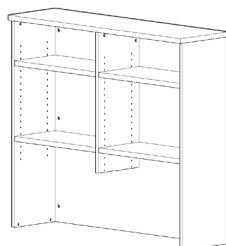

**B027: 1200 HUTCH**

- 1200mmW x 1080mmH x 335mmD
- 25mm Top/Shelves and 18mm Back/Sides
- 4 x Adjustable Shelves (allows for full size binder folders)
- Internal shelf measurement: 565mmW x 290mmD



**B028: 1500 HUTCH**

- 1500mmW x 1080mmH x 335mmD
- 25mm Top/Shelves and 18mm Back/Sides
- 4 x Adjustable Shelves (allows for full size binder folders)
- Internal shelf measurement: 716mmW x 290mmD

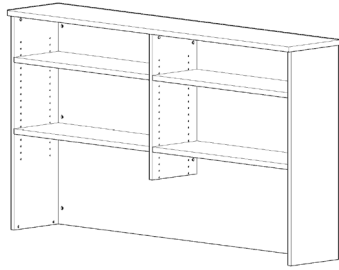

**B029: 1800 HUTCH**

- 1800mmW x 1080mmH x 335mmD
- 25mm Top/Shelves and 18mm Back/Sides
- 4 x Adjustable Shelves (allows for full size binder folders)
- Internal shelf measurement: 716mmW x 290mmD

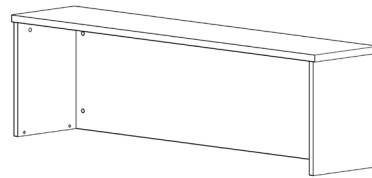

**B031: 1800 HOB**

- 1800mmW x 450mmH x 320mmD
- 25mm Top and 18mm Back/Sides

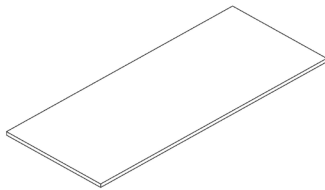

**TOP1890B0: 1800 x 900 TOP**

- 1800mmW x 900mmD x 25mmT
- Matching 2mm ABS Edging
- No cable access holes - available for \$20+GST including 60mm cover
- Reversible top - no grommet or D-Nut inserts

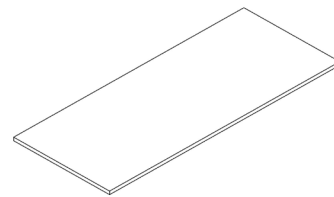

**TOP1875B0: 1800 x 750 TOP**

- 1800mmW x 750mmD x 25mmT
- Matching 2mm ABS Edging
- No cable access holes - available for \$20+GST including 60mm cover
- Reversible top - no grommet or D-Nut inserts

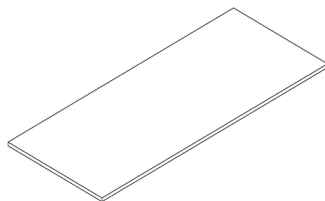

**TOP1575B0: 1500 x 750 TOP**

- 1500mmW x 750mmD x 25mmT
- Matching 2mm ABS Edging
- No cable access holes - available for \$20+GST including 60mm cover
- Reversible top - no grommet or D-Nut inserts

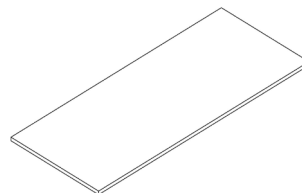

**TOP1275B0: 1200 x 750 TOP**

- 1200mmW x 750mmD x 25mmT
- Matching 2mm ABS Edging
- No cable access holes - available for \$20+GST including 60mm cover
- Reversible top - no grommet or D-Nut inserts

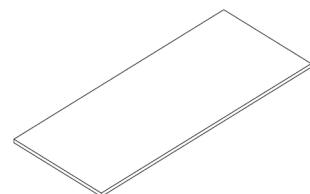

**TOP126B0: 1200 x 600 TOP**

- 1200mmW x 600mmD x 25mmT
- Matching 2mm ABS Edging
- No cable access holes - available for \$20+GST including 60mm cover
- Reversible top - no grommet or D-Nut inserts

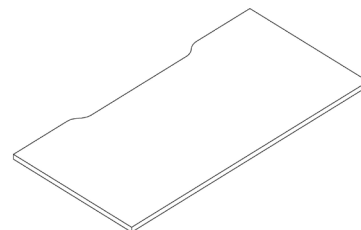

**T1B0: 1800 x 750 SCALLOP TOP**

- 1800mmW x 750mmD x 25mmT
- Matching 2mm ABS Edging
- Cable access scallop: 600mmW x 45mmD
- Reversible top - no grommet or D-Nut inserts

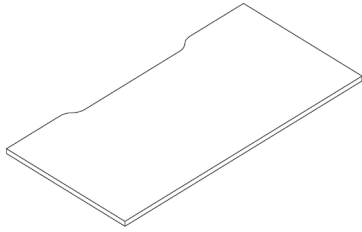

**T2B0: 1500 x 750 SCALLOP TOP**

- 1500mmW x 750mmD x 25mmT
- Matching 2mm ABS Edging
- Cable access scallop: 600mmW x 45mmD
- Reversible top - no grommet or D-Nut inserts

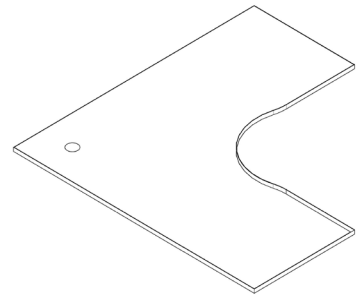

**T3B0: 1800 x 1800 x 750 TOP**

- 1800mmW x 1800mmW x 750mmD x 25mmT
- Matching 2mm ABS Edging
- Cable access hole in corner with 80mm cover
- Reversible top - no grommet or D-Nut inserts

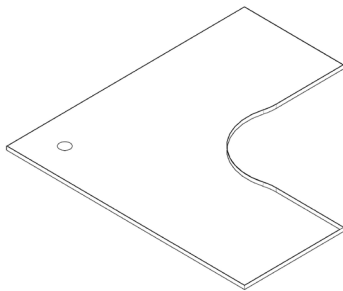

**T4B0: 1800 x 1500 x 750 TOP**

- 1800mmW x 1500mmW x 750mmD x 25mmT
- Matching 2mm ABS Edging
- Cable access hole in corner with 80mm cover
- Reversible top - no grommet or D-Nut inserts

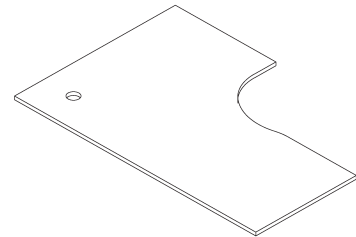

**T5B0: 1800 x 1200 x 750 TOP**

- 1800mmW x 1200mmW x 750mmD x 25mmT
- Matching 2mm ABS Edging
- Cable access hole in corner with 80mm cover
- Reversible top - no grommet or D-Nut inserts

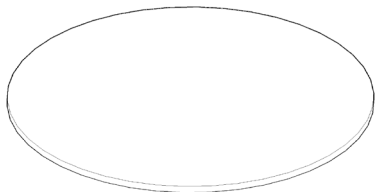

**TOP1050DIABO: 1050 ROUND TOP**

- 1050mmDia x 25mmT
- Matching 2mm ABS Edging
- Reversible top - no grommet or D-Nut inserts

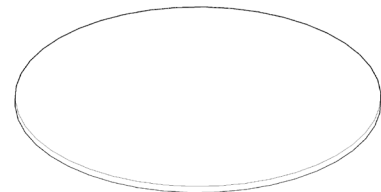

**TOP900DIABO: 900 ROUND TOP**

- 900mmDia x 25mmT
- Matching 2mm ABS Edging
- Reversible top - no grommet or D-Nut inserts

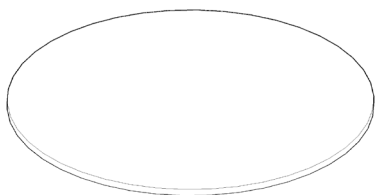

**TOP600DIABO: 600 ROUND TOP**

- 600mmDia x 25mmT
- Matching 2mm ABS Edging
- Reversible top - no grommet or D-Nut inserts

# BLEND WHITE RANGE



**DESIGNED TO CATER TO BOTH COMMERCIAL AND HOME OFFICE ENVIRONMENTS, THIS RANGE OFFERS A SEAMLESS COMBINATION OF AFFORDABILITY AND VERSATILITY. WITH A COMPREHENSIVE SELECTION OF DESKS, WORKSTATIONS, AND STORAGE OPTIONS, THE BLEND WHITE RANGE PROVIDES A COHESIVE AND COMPLIMENTARY SET OF SOLUTIONS FOR YOUR WORKSPACE NEEDS.**

## **FEATURES AND SPECIFICATIONS:**

- 25mm tops over 25mm end panels for corner workstation and returns (18mm modesty)
- 25 mm top/base/shelves over 18mm back/sides/doors on credenzas, bookcases and hutches
- Matte-black hardware (handles, locks and cable access covers)
- CL2 Locks (2-keys) for mobile pedestal, credenzas and cabinets
- Soft close 3D adjustable cabinet hinges included with Stationery Cabinet and Utility Cabinet
- Adjustable screw in leveling feet on all desks, corner workstations and returns (D Nut)
- 25mm adjustable wind-up leveling feet on all storage items
- 60mm cable access holes with black covers for desking, corner workstations and returns
- 80mm cable access holes for corner desk tops
- E1 Melamine Particle Board
- 2mm matching ABS Edging on exposed face edges
- 1mm matching ABS edging on exposed bottom edges (modesty, back, side and end panels)
- 40mm overhang on rear edge/sides of desks, corner workstation and returns to accommodate commercial skirting
- Colour: White (blends seamlessly with locally manufactured Laminex White 200 joinery)
- Compatible with Blend Barrel Oak Range (refer to page 58 for information on Blend Range buying options)
- Warranty: 5 year warranty

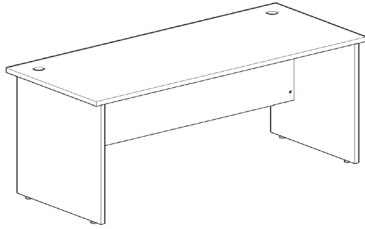

**BW36: 1800 x 750 DESK**

- 1800mmL x 750mmD x 720mmH
- 25mm Top/End Panels and 18mm Modesty (3/4)
- 720mm desk height with adjustable feet
- 2 x 60mm cable access holes with black covers
- 40mm overhang (sides/rear) for commercial skirting

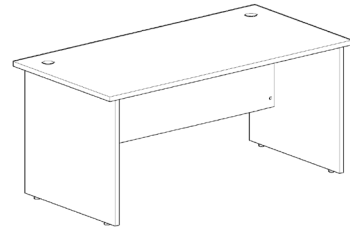

**BW2: 1500 x 750 DESK**

- 1500mmL x 750mmD x 720mmH
- 25mm Top/End Panels and 18mm Modesty (3/4)
- 720mm desk height with adjustable feet
- 2 x 60mm cable access holes with black covers
- 40mm overhang (sides/rear) for commercial skirting

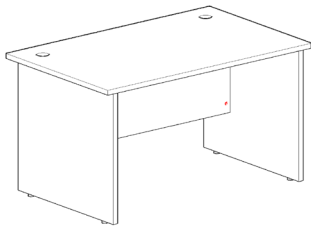

**BW3: 1200 x 750 DESK**

- 1200mmL x 750mmD x 720mmH
- 25mm Top/End Panels and 18mm Modesty (3/4)
- 720mm desk height with adjustable feet
- 2 x 60mm cable access holes with black covers
- 40mm overhang (sides/rear) for commercial skirting

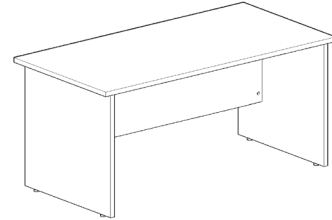

**BW4: 1200 x 600 DESK**

- 1200mmL x 750mmD x 720mmH
- 25mm Top/End Panels and 18mm Modesty (3/4)
- 720mm desk height with adjustable feet
- No cable access holes
- 40mm overhang (sides/rear) for commercial skirting

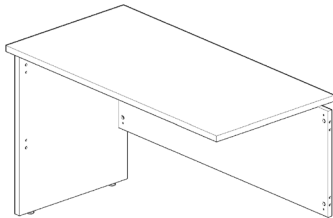

**BW5: 1200 x 600 RETURN**

- 1200mmL x 600mmD x 720mmH
- 25mm Top/End Panels and 18mm Modesty (3/4)
- 720mm desk height with adjustable feet
- 40mm overhang (sides/rear) for commercial skirting
- Compatible with Desk or Corner Unit (600mmD - BW126)
- Reversible; Left-hand or Right-hand assembly

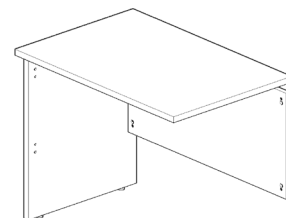

**BW6: 900 x 600 RETURN**

- 900mmL x 600mmD x 720mmH
- 25mm Top/End Panels and 18mm Modesty (3/4)
- 720mm desk height with adjustable feet
- 40mm overhang (sides/rear) for commercial skirting
- Compatible with Desk or Corner Unit (600mmD - BW126)
- Reversible; Left-hand or Right-hand assembly

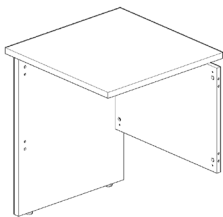

**BW8: 600 x 600 RETURN**

- 600mmL x 600mmD x 720mmH
- 25mm Top/End Panels and 18mm Modesty (3/4)
- 720mm desk height with adjustable feet
- 40mm overhang (sides/rear) for commercial skirting
- Compatible with Desk or Corner Unit (600mmD - BW126)
- Reversible; Left-hand or Right-hand assembly

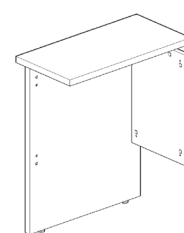

**BW9: 300 x 600 RETURN**

- 300mmL x 600mmD x 720mmH
- 25mm Top/End Panels and 18mm Modesty (3/4)
- 720mm desk height with adjustable feet
- 40mm overhang (sides/rear) for commercial skirting
- Compatible with Desk or Corner Unit (600mmD - BW126)
- Reversible; Left-hand or Right-hand assembly

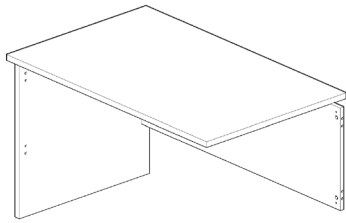

**BW575: 1200 x 750 RETURN**

- 1200mmL x 750mmD x 720mmH
- 25mm Top/End Panels and 18mm Modesty (3/4)
- 720mm desk height with adjustable feet
- 40mm overhang (sides/rear) for commercial skirting
- Compatible with Desk or Corner Unit (750mmD - BW1275)
- Reversible; Left-hand or Right-hand assembly

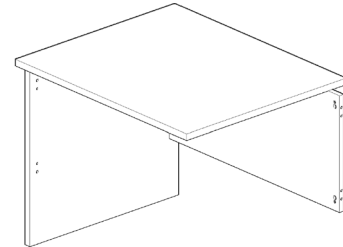

**BW675: 900 x 750 RETURN**

- 900mmL x 750mmD x 720mmH
- 25mm Top/End Panels and 18mm Modesty (3/4)
- 720mm desk height with adjustable feet
- 40mm overhang (sides/rear) for commercial skirting
- Compatible with Desk or Corner Unit (750mmD - BW1275)
- Reversible; Left-hand or Right-hand assembly

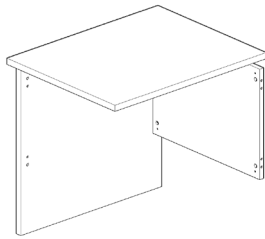

**BW875: 600 x 750 RETURN**

- 600mmL x 750mmD x 720mmH
- 25mm Top/End Panels and 18mm Modesty (3/4)
- 720mm desk height with adjustable feet
- 40mm overhang (sides/rear) for commercial skirting
- Compatible with Desk or Corner Unit (750mmD - BW1275)
- Reversible; Left-hand or Right-hand assembly

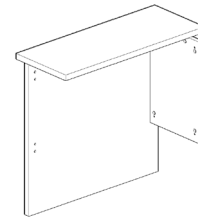

**BW975: 300 x 750 RETURN**

- 300mmL x 750mmD x 720mmH
- 25mm Top/End Panels and 18mm Modesty (3/4)
- 720mm desk height with adjustable feet
- 40mm overhang (sides/rear) for commercial skirting
- Compatible with Desk or Corner Unit (750mmD - BW1275)
- Reversible; Left-hand or Right-hand assembly

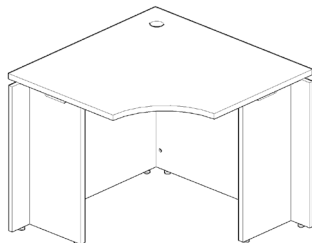

**BW126: 600D CORNER UNIT**

- 900mmL x 900mmW x 600mmD x 720mmH
- 25mm Top/ End Panels and 18mm Modesty (full)
- 720mm desk height with adjustable feet
- 40mm overhang (sides/rear) for commercial skirting
- Compatible with 600mmD Returns
- Cable access holes in Top, Modesty and Legs

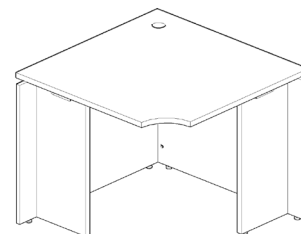

**BW1275: 750D CORNER UNIT**

- 900mmL x 900mmW x 750mmD x 720mmH
- 25mm Top/ End Panels and 18mm Modesty (full)
- 720mm desk height with adjustable feet
- 40mm overhang (sides/rear) for commercial skirting
- Compatible with 750mmD Returns
- Cable access holes in Top, Modesty and Legs

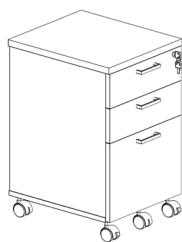

**BW14: MOBILE PEDESTAL 2+1**

- 675mmH x 405mmW x 470mmD
- 25mm Top and Base / 18mm Carcass and Drawer Fronts
- Factory assembled - castors and handles to be fitted
- Black handles and lock (Black CL2 Lock - 2 Keys)
- Anti-tilt castor fitted to base of file drawer
- 2-locking castors + 2 free spinning castors



**BW19: 1800 x 900 BOOKCASE**

- 1800mmH x 900mmW x 320mmD
- 25mm Top/Shelves/Base and 18mm Back/Sides
- 1 x Fixed Shelf + 3 x Adjustable Shelves (spacing allows for full size binder folders)
- Internal shelf measurement: 860mmW x 292mmD
- Adjustable 25mm nylon leveling feet





**BW43: 900 x 900 BOOKCASE**

- 900mmH x 900mmW x 320mmD
- 25mm Top/Shelves/Base and 18mm Back/Sides
- 2 x Adjustable Shelves (allows for full size binder folders)  
Internal shelf measurement: 860mmW x 292mmD
- Adjustable 25mm nylon leveling feet



**BW20: STATIONERY CABINET**

- 1800mmH x 900mmW x 450mmD
- 25mm Top/Shelves/Base and 18mm Back/Doors/Sides
- 1 x Fixed Shelf + 3 x Adjustable Shelves
- Soft-close 3D adjustable cabinet hinges
- Black handles and lock (CL2 lock + 2 keys)
- Adjustable 25mm nylon leveling feet



**BW22: UTILITY CABINET**

- 900mmH x 900mmW x 450mmD
- 25mm Top/Shelves/Base and 18mm Back/Doors/Sides
- 2 x Adjustable Shelves
- Soft-close 3D adjustable cabinet hinges
- Black handles and lock (CL2 lock + 2 keys)
- Adjustable 25mm nylon leveling feet

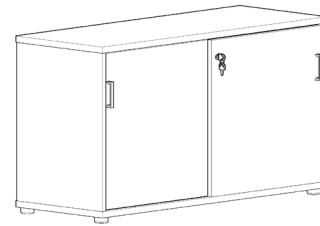

**BW23: 1200 CREDENZA**

- 1200mmW x 720mmH x 450mmD
- 25mm Top/Shelves/Base and 18mm Back/Sides/Doors
- 2 x Adjustable Shelves
- Internal shelf measurement: 570mmW x 353mmD
- Black handles and lock (CL2 lock - 2 keys)
- Adjustable 25mm nylon leveling feet

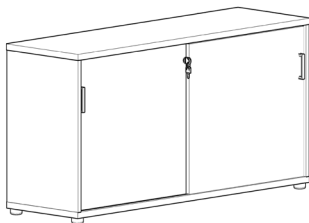

**BW24: 1500 CREDENZA**

- 1500mmW x 720mmH x 450mmD
- 25mm Top/Shelves/Base and 18mm Back/Sides/Doors
- 2 x Adjustable Shelves
- Internal shelf measurement: 720mmW x 353mmD
- Black handles and lock (CL2 lock - 2 keys)
- Adjustable 25mm nylon leveling feet

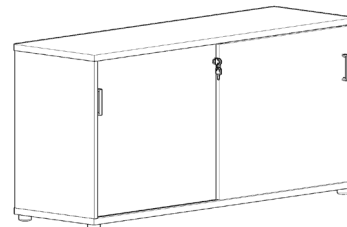

**BW25: 1800 CREDENZA**

- 1800mmW x 720mmH x 450mmD
- 25mm Top/Shelves/Base and 18mm Back/Sides/Doors
- 2 x Adjustable Shelves
- Internal shelf measurement: 870mmW x 353mmD
- Black handles and lock (CL2 lock - 2 keys)
- Adjustable 25mm nylon leveling feet

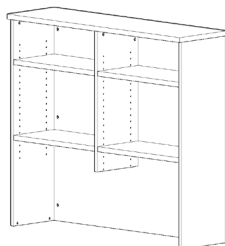

**BW27: 1200 HUTCH**

- 1200mmW x 1080mmH x 335mmD
- 25mm Top/Shelves and 18mm Back/Sides
- 4 x Adjustable Shelves (allows for full size binder folders)
- Internal shelf measurement: 565mmW x 290mmD



**BW28: 1500 HUTCH**

- 1500mmW x 1080mmH x 335mmD
- 25mm Top/Shelves and 18mm Back/Sides
- 4 x Adjustable Shelves (allows for full size binder folders)
- Internal shelf measurement: 716mmW x 290mmD

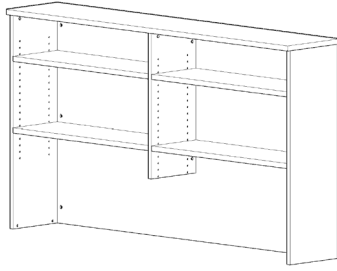

**BW29: 1800 HUTCH**

- 1800mmW x 1080mmH x 335mmD
- 25mm Top/Shelves and 18mm Back/Sides
- 4 x Adjustable Shelves (allows for full size binder folders)
- Internal shelf measurement: 716mmW x 290mmD

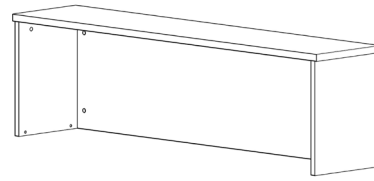

**BW31: 1800 HOB**

- 1800mmW x 450mmH x 320mmD
- 25mm Top and 18mm Back/Sides

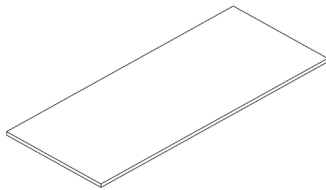

**TOP1890W: 1800 x 900 TOP**

- 1800mmW x 900mmD x 25mmT
- Matching 2mm ABS Edging
- No cable access holes - available for \$20+GST including 60mm cover
- Reversible top - no grommet or D-Nut inserts

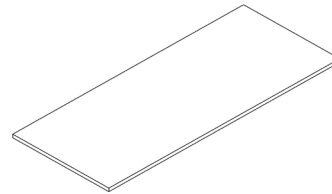

**TOP1875W: 1800 x 750 TOP**

- 1800mmW x 750mmD x 25mmT
- Matching 2mm ABS Edging
- No cable access holes - available for \$20+GST including 60mm cover
- Reversible top - no grommet or D-Nut inserts

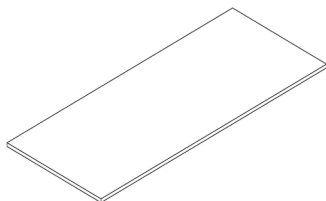

**TOP1575W: 1500 x 750 TOP**

- 1500mmW x 750mmD x 25mmT
- Matching 2mm ABS Edging
- No cable access holes - available for \$20+GST including 60mm cover
- Reversible top - no grommet or D-Nut inserts

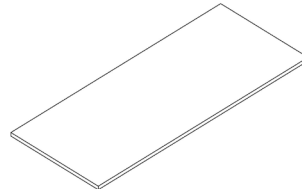

**TOP1275W: 1200 x 750 TOP**

- 1200mmW x 750mmD x 25mmT
- Matching 2mm ABS Edging
- No cable access holes - available for \$20+GST including 60mm cover
- Reversible top - no grommet or D-Nut inserts

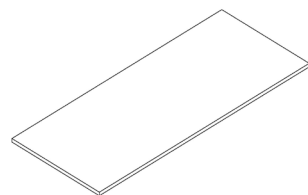

**TOP126W: 1200 x 600 TOP**

- 1200mmW x 600mmD x 25mmT
- Matching 2mm ABS Edging
- No cable access holes - available for \$20+GST including 60mm cover
- Reversible top - no grommet or D-Nut inserts

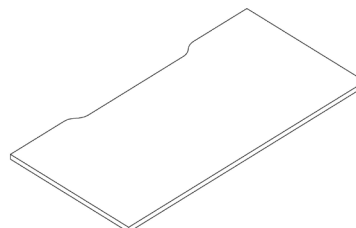

**T1W: 1800 x 750 SCALLOP TOP**

- 1800mmW x 750mmD x 25mmT
- Matching 2mm ABS Edging
- Cable access scallop: 600mmW x 45mmD
- Reversible top - no grommet or D-Nut inserts

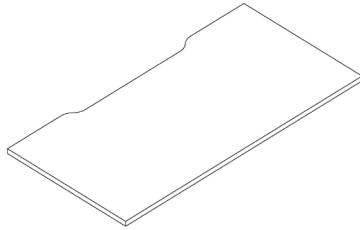

**T2W: 1500 x 750 SCALLOP TOP**

- 1500mmW x 750mmD x 25mmT
- Matching 2mm ABS Edging
- Cable access scallop: 600mmW x 45mmD
- Reversible top - no grommet or D-Nut inserts

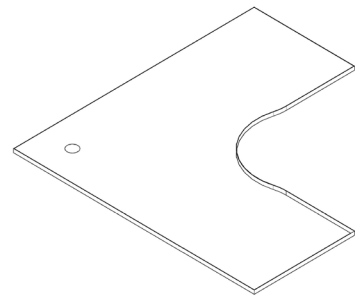

**T3W: 1800 x 1800 x 750 TOP**

- 1800mmW x 1800mmW x 750mmD x 25mmT
- Matching 2mm ABS Edging
- Cable access hole in corner with 80mm cover
- Reversible top - no grommet or D-Nut inserts

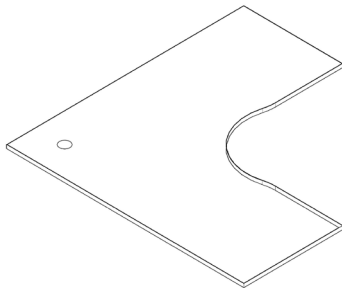

**T4W: 1800 x 1500 x 750 TOP**

- 1800mmW x 1500mmW x 750mmD x 25mmT
- Matching 2mm ABS Edging
- Cable access hole in corner with 80mm cover
- Reversible top - no grommet or D-Nut inserts

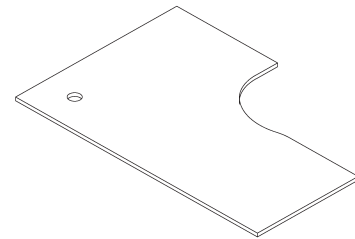

**T5W: 1800 x 1200 x 750 TOP**

- 1800mmW x 1200mmW x 750mmD x 25mmT
- Matching 2mm ABS Edging
- Cable access hole in corner with 80mm cover
- Reversible top - no grommet or D-Nut inserts

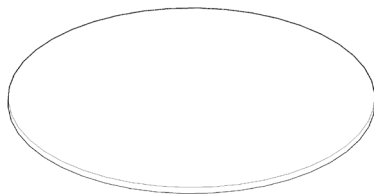

**TOP1050DIAW: 1050 ROUND TOP**

- 1050mmDia x 25mmT
- Matching 2mm ABS Edging
- Reversible top - no grommet or D-Nut inserts

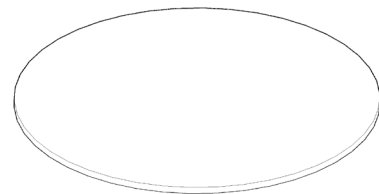

**TOP900DIAW: 900 ROUND TOP**

- 900mmDia x 25mmT
- Matching 2mm ABS Edging
- Reversible top - no grommet or D-Nut inserts

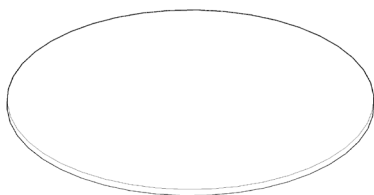

**TOP600DIAW: 600 ROUND TOP**

- 600mmDia x 25mmT
- Matching 2mm ABS Edging
- Reversible top - no grommet or D-Nut inserts



# BLEND BUYING OPTIONS

The Blend Range has been designed to be interchangeable between the Blend Barrel Oak and Blend White colours to allow for flexible combinations for home or commercial office settings.



Customers can now choose from the following colour combinations or mix & match as required:

- All Oak
- All White
- Blend Oak over White (component mix listed below)
- Blend White over Oak (component mix listed below)

## BLEND OAK OVER WHITE:

	COMPONENT	BARREL OAK COLOUR	WHITE COLOUR
	DESK TOP	✓	
	MODESTY PANEL		✓
	END PANEL		✓
	TOP/BASE	✓	
	SHELVES	✓	
	DOORS	✓	
	BACK/SIDE PANELS		✓
	CENTRE DIVIDER		✓

## BLEND WHITE OVER OAK:

	COMPONENT	BARREL OAK COLOUR	WHITE COLOUR
	DESK TOP		✓
	MODESTY PANEL	✓	
	END PANEL	✓	
	TOP/BASE		✓
	SHELVES		✓
	DOORS		✓
	BACK/SIDE PANELS	✓	
	CENTRE DIVIDER	✓	

<b>PRODUCT DESCRIPTION</b>	<b>BLEND OAK OVER WHITE ORDER CODE</b>	<b>BLEND WHITE OVER OAK ORDER CODE</b>
1800 x 750 DESK	B036A / BW36B	BW36A / B036B
1500 x 750 DESK	B02A / BW2B	BW2A / B02B
1200 x 750 DESK	B03A / BW3B	BW3A / B03B
1200 x 600 DESK	B04A / BW4B	BW4A / B04B
1200 x 600 RETURN	B05A / BW5B	BW5A / B05B
900 x 600 RETURN	B06A / BW6B	BW6A / B06B
600 x 600 RETURN	B08A / BW8B	BW8A / B08B
300 x 600 RETURN	B09A / BW9B	BW9A / B09B
1200 x 750 RETURN	B0575A / BW575B	BW575A / B0575B
900 x 750 RETURN	B0675A / BW675B	BW675A / B0675B
600 x 750 RETURN	B0875A / BW875B	BW875A / B0875B
300 x 750 RETURN	B0975A / BW975B	BW975A / B0975B
600 CORNER UNIT	B0126A / BW126B	BW126A / B0126B
750 CORNER UNIT	B01275A / BW1275B	BW1275A / B01275B
1800 x 900 BOOKCASE	B019A / BW19B	BW19A / B019B
900 x 900 BOOKCASE	B043A / BW43B	BW43A / B043B
STATIONERY CABINET	B020A / BW20B	BW20A / B020B
UTILITY CABINET	B022A / BW22B	BW22A / B022B
1200 CREDENZA	B023A / BW23B	BW23A / B023B
1500 CREDENZA	B024A / BW24B	BW24A / B024B
1800 CREDENZA	B025A / BW25B	BW25A / B025B
1200 HUTCH	B027A / BW27B	BW27A / B027B
1500 HUTCH	B028A / BW28B	BW28A / B028B
1800 HUTCH	B029A / BW29B	BW29A / B029B
1800 HOB	B031A / BW31B	BW31A / B031B



PICTURED: B02



PICTURED: BW2



PICTURED: B02A / BW2B



PICTURED: BW2A / B02B



PICTURED: B0126  
B09  
B08  
B027



PICTURED: BW126  
BW9  
BW8  
BW27



PICTURED: B0126A / BW126B  
B09A / BW9B  
B08A / BW8B  
B027A / BW27B



PICTURED: BW126A / B0126B  
BW9A / B09B  
BW8A / B08B  
BW27A / B027B



PICTURED: B023



PICTURED: BW23



PICTURED: B023A / BW23B



PICTURED: BW23A / B023B



PICTURED: B019



PICTURED: BW19



PICTURED: B019A / BW19B



PICTURED: BW19A / B019B



PICTURED: B020



PICTURED: BW20



PICTURED: B020A / BW20B



PICTURED: BW20A / B020B

# BLEND WORKSTATION SIZES

The Blend Corner Workstation Range is available in 20 size combinations ranging from 1200mm x 1200mm to 2100mm x 2100mm. Workstations can be ordered in either 600mmD or 750mmD.

## WORKSTATION SIZE 600 DEEP

## COMPONENT ORDER CODES \* DENOTES COLOUR (O=OAK W=WHITE)

1200W x 1200W x 600D	B*126 + B*9 + B*9
1200W x 1500W x 600D	B*126 + B*9 + B*8
1200W x 1800W x 600D	B*126 + B*9 + B*6
1200W x 2100W x 600D	B*126 + B*9 + B*5
1500W x 1500W x 600D	B*126 + B*8 + B*8
1500W x 1800W x 600D	B*126 + B*8 + B*6
1500W x 2100W x 600D	B*126 + B*8 + B*5
1800W x 1800W x 600D	B*126 + B*6 + B*6
1800W x 2100W x 600D	B*126 + B*6 + B*5
2100W x 2100W x 600D	B*126 + B*5 + B*5

## WORKSTATION SIZE 750 DEEP

## COMPONENT ORDER CODES \* DENOTES COLOUR (O=OAK W=WHITE)

1200W x 1200W x 750D	B*1275 + B*975 + B*975
1200W x 1500W x 750D	B*1275 + B*975 + B*875
1200W x 1800W x 750D	B*1275 + B*975 + B*675
1200W x 2100W x 750D	B*1275 + B*975 + B*575
1500W x 1500W x 750D	B*1275 + B*875 + B*875
1500W x 1800W x 750D	B*1275 + B*875 + B*675
1500W x 2100W x 750D	B*1275 + B*875 + B*575
1800W x 1800W x 750D	B*1275 + B*675 + B*675
1800W x 2100W x 750D	B*1275 + B*675 + B*575
2100W x 2100W x 750D	B*1275 + B*575 + B*575



# STELLA PILOT RANGE



**DESIGNED TO CATER TO BOTH COMMERCIAL AND HOME OFFICE ENVIRONMENTS, THIS RANGE OFFERS A COMPREHENSIVE SELECTION OF DESKS, WORKSTATIONS, AND STORAGE OPTIONS. THE PILOT RANGE INCLUDES A COMBINATION OF SIZES ALLOWING FOR MULTIPLE WORKSTATION CONFIGURATIONS AND OFFICE LAYOUTS.**

## **FEATURES AND SPECIFICATIONS:**

- 25mm tops over 25mm end panels; corner workstation and returns (18mm modesty)
- 25 mm top/base/shelves over 18mm back, side, doors; credenzas, bookcases and hutches
- Satin Chrome hardware (handles and locks)
- CL2 Locks (2-keys) for mobile pedestals, credenzas and cabinets
- Adjustable screw in leveling feet on all desks, corner workstations and returns
- 25mm adjustable wind-up leveling feet on all storage items
- 60mm cable access holes with matching beech covers for deskings, corner workstations and returns
- E1 Melamine Particle Board
- 2mm matching ABS Edging on exposed face edges
- 1mm matching ABS edging on exposed bottom edges (modesty, back, side and end panels)
- 40mm overhang on rear edge/sides of desks, corner workstation and returns to accommodate commercial skirting
- Colour: Beech over Ironstone
- Warranty: 3 year warranty

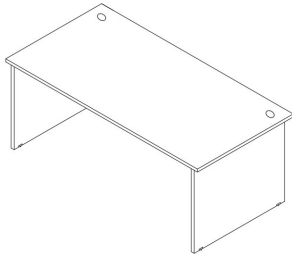

**P1: 1800 x 900 DESK**

- 1800mmL x 900mmD x 720mmH
- 25mm Top/End Panels and 18mm Modesty (3/4)
- 720mm desk height with adjustable feet
- 2 x 60mm cable access holes with beech covers

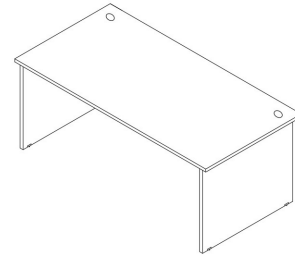

**P36: 1800 x 750 DESK**

- 1800mmL x 750mmD x 720mmH
- 25mm Top/End Panels and 18mm Modesty (3/4)
- 720mm desk height with adjustable feet
- 2 x 60mm cable access holes with beech covers

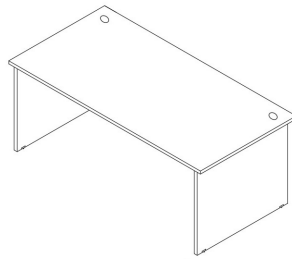

**P2: 1500 x 750 DESK**

- 1500mmL x 750mmD x 720mmH
- 25mm Top/End Panels and 18mm Modesty (3/4)
- 720mm desk height with adjustable feet
- 2 x 60mm cable access holes with beech covers

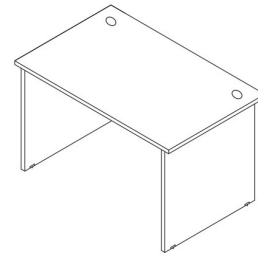

**P3: 1200 x 750 DESK**

- 1200mmL x 750mmD x 720mmH
- 25mm Top/End Panels and 18mm Modesty (3/4)
- 720mm desk height with adjustable feet
- 2 x 60mm cable access holes with beech covers

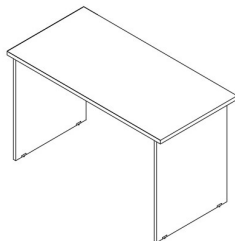

**P4: 1200 x 600 DESK**

- 1200mmL x 600mmD x 720mmH
- 25mm Top/End Panels and 18mm Modesty (3/4)
- 720mm desk height with adjustable feet
- No cable access holes

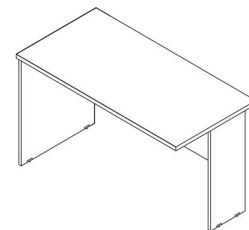

**P5: 1200 x 600 RETURN**

- 1200mmL x 600mmD x 720mmH
- 25mm Top/End Panels and 18mm Modesty (3/4)
- 720mm desk height with adjustable feet
- No cable access holes
- Universal assembly (left or right hand)

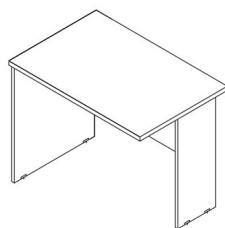

**P6: 900 x 600 RETURN**

- 900mmL x 600mmD x 720mmH
- 25mm Top/End Panels and 18mm Modesty (3/4)
- 720mm desk height with adjustable feet
- No cable access holes
- Universal assembly (left or right hand)

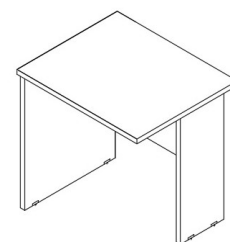

**P80: 600 x 600 RETURN**

- 600mmL x 600mmD x 720mmH
- 25mm Top/End Panels and 18mm Modesty (3/4)
- 720mm desk height with adjustable feet
- No cable access holes
- Universal assembly (left or right hand)

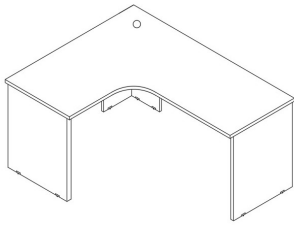

**P11L: 1500 x 1200 DESK L/H**

- 1500mmL x 1200mmW x 600mmD x 720mmH
- 25mm Top/End Panels and 18mm Modesty (3/4)
- 720mm desk height with adjustable feet
- Single cable access hole in corner
- 1200mmL on the LEFT when sitting at desk

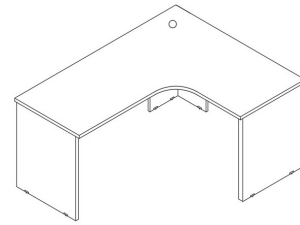

**P11R: 1500 x 1200 DESK R/H**

- 1500mmL x 1200mmW x 600mmD x 720mmH
- 25mm Top/End Panels and 18mm Modesty (3/4)
- 720mm desk height with adjustable feet
- Single cable access hole in corner
- 1200mmL on the RIGHT when sitting at desk

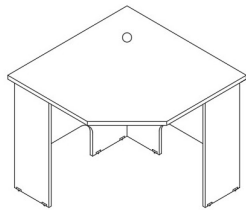

**P12: 900 x 900 CORNER DESK**

- 900mmW x 99mmW x 600mmD x 720mmH
- 25mm Top/End Panels and 18mm Modesty (3/4)
- 720mm desk height with adjustable feet
- Single cable access hole in corner
- Compatible with P5, P6 and P80 Returns

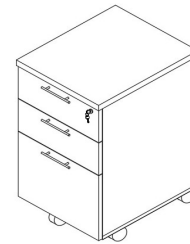

**P14: MOBILE PEDESTAL**

- 675mmH x 415mmW x 500mmD
- 25mm Top and Base / 18mm Carcass and Drawer Fronts
- Factory assembled - castors and handles to be fitted
- Satin Chrome handles and lock (Black CL2 Lock - 2 Keys)
- Anti-tilt castor fitted to base of file drawer
- Pencil tray and adjustable file rail included

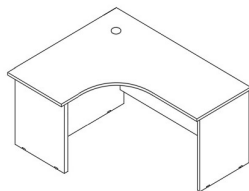

**P54L: 1800 x 1200 DESK L/H**

- 1800mmL x 1200mmW x 720mmH (main desk 750mmD and return side 600mmD)
- 25mm Top/End Panels and 18mm Modesty (3/4)
- Single cable access hole in corner
- 1200mmL on the LEFT when sitting at desk
- Compatible with P55 and P56 returns

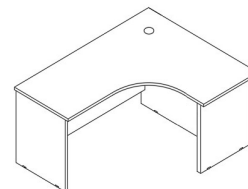

**P54R: 1800 x 1200 DESK R/H**

- 1800mmL x 1200mmW x 720mmH (main desk 750mmD and return side 600mmD)
- 25mm Top/End Panels and 18mm Modesty (3/4)
- Single cable access hole in corner
- 1200mmL on the RIGHT when sitting at desk
- Compatible with P55 and P56 returns

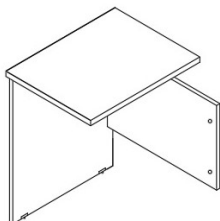

**P55: 300 x 600 RETURN**

- 300mmL x 600mmD x 720mmH
- Compatible only with P54 Desk - acts as extension kit for 1200 x 600 return side to extend desk to 1800mm x 1500mm
- Universal assembly (left or right hand)

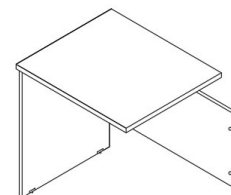

**P56: 600 x 600 RETURN**

- 600mmL x 600mmD x 720mmH
- Compatible only with P54 Desk - acts as extension kit for 1200 x 600 return side to extend desk to 1800mm x 1800mm
- Universal assembly (left or right hand)

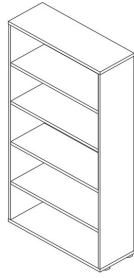

**P19: 1800 x 900 BOOKCASE**

- 1800mmH x 900mmW x 330mmD
- 25mm Top/Shelves/Base and 18mm Back/Sides
- 1 x Fixed Shelf + 3 Adjustable Shelves (spacing allows for full size binder folders)
- Adjustable 25mm nylon leveling feet

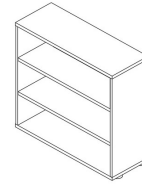

**P42: 900 x 900 BOOKCASE**

- 900mmH x 900mmW x 330mmD
- 25mm Top/Shelves/Base and 18mm Back/Sides
- 2 x Adjustable Shelves (allows for full size binder folders)
- Adjustable 25mm nylon leveling feet

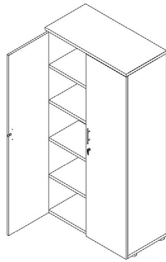

**P20: STATIONERY CABINET**

- 1800mmH x 900mmW x 450mmD
- 25mm Top/Shelves/Base and 18mm Back/Doors/Sides
- 1 x Fixed Shelf + 3 Adjustable Shelves
- Satin Chrome handles and lock (CL2 lock + 2 keys)
- Adjustable 25mm nylon leveling feet

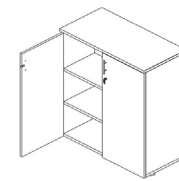

**P37: UTILITY CABINET**

- 900mmH x 900mmW x 600mmD
- 25mm Top/Shelves/Base and 18mm Back/Doors/Sides
- 2 adjustable Shelves
- Satin Chrome handles and lock (CL2 lock + 2 keys)
- Adjustable 25mm nylon leveling feet

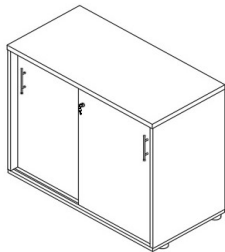

**P23: 1200 CREDENZA**

- 1200mmW x 720mmH x 450mmD
- 25mm Top/Base and 18mm Shelves/Sides/Doors
- 2 Adjustable Shelves
- Satin Chrome handles and lock (CL2 lock - 2 keys)
- Adjustable 25mm nylon leveling feet

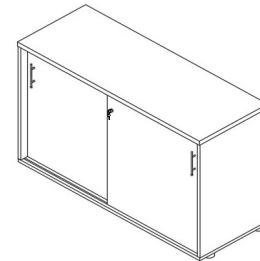

**P24: 1500 CREDENZA**

- 1500mmW x 720mmH x 450mmD
- 25mm Top/Base and 18mm Shelves/Sides/Doors
- 2 Adjustable Shelves
- Satin Chrome handles and lock (CL2 lock - 2 keys)
- Adjustable 25mm nylon leveling feet

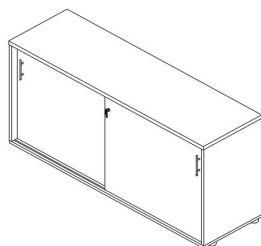

**P25: 1800 CREDENZA**

- 1800mmW x 720mmH x 450mmD
- 25mm Top/Base and 18mm Shelves/Sides/Doors
- 2 Adjustable Shelves
- Satin Chrome handles and lock (CL2 lock - 2 keys)
- Adjustable 25mm nylon leveling feet

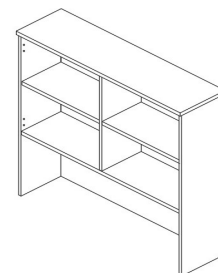

**P27: 1200 HUTCH**

- 1200mmW x 1205mmH x 313mmD
- 25mm Top/Shelves and 18mm Back/Sides
- 1 Fixed Shelf + 2 Adjustable Shelves (allows for full size binder folders)
- Compatible with Hutch Door Kit (P82)

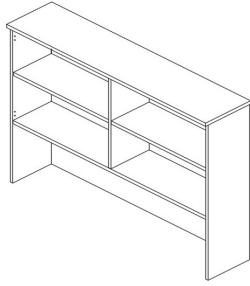

**P28: 1500 HUTCH**

- 1500mmW x 1205mmH x 313mmD
- 25mm Top/Shelves and 18mm Back/Sides
- 1 Fixed Shelf + 2 Adjustable Shelves (allows for full size binder folders)
- Compatible with Hutch Door Kit (P83)

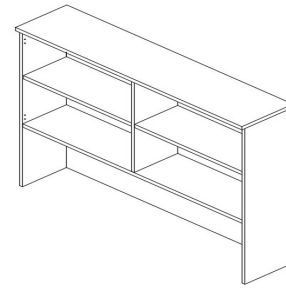

**P29: 1800 HUTCH**

- 1800mmW x 1205mmH x 313mmD
- 25mm Top/Shelves and 18mm Back/Sides
- 1 Fixed Shelf + 2 Adjustable Shelves (allows for full size binder folders)
- Compatible with Hutch Door Kit (P84)

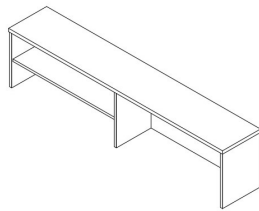

**P31: 1800 HOB**

- 1800mmW x 425mmH x 300mmD
- 25mm Top/Shelves and 18mm Back/Sides
- 1 Adjustable Shelf - can be installed on either side of centre divider

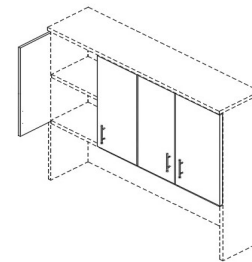

**P82: 1200 HUTCH DOOR KIT**

- Compatible with 1200 Hutch (P27)
- Kit includes 4 doors with Satin Chrome handles
- Kit includes Clip on/off hinges
- Not locking

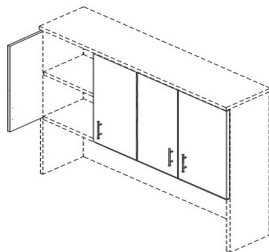

**P83: 1500 HUTCH DOOR KIT**

- Compatible with 1500 Hutch (P28)
- Kit includes 4 doors with Satin Chrome handles
- Kit includes Clip on/off hinges
- Not locking

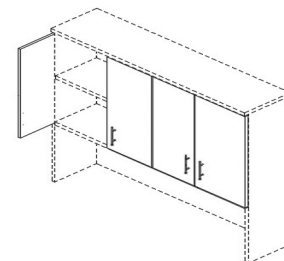

**P84: 1800 HUTCH DOOR KIT**

- Compatible with 1800 Hutch (P29)
- Kit includes 4 doors with Satin Chrome handles
- Kit includes Clip on/off hinges
- Not locking

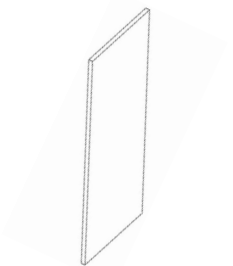

**P38: BRIDGING LEG**

- Compatible with L-Shape Desk (P11), Returns (P5, P6 and P80) to extend multiple returns for larger corner workstations.
- 260mmW x 695mmH x 25mmT (finished desk height 720mmH)

# MELAMINE FURNITURE PARTS

## BLEND RANGE SPARE PARTS:

### PRODUCT DESCRIPTION

CREDENZA PUSH LOCK (CL2 - 2 KEYS, BLACK FINISH)
MOBILE PEDESTAL LOCK (CL2 - 2 KEYS, BLACK FINISH)
STATIONERY CUPBOARD LOCK (CL2 - 2 KEYS, BLACK FINISH)
DOOR HANDLE (BLACK FINISH)
60MM CABLE COVER (BLACK FINISH)
80MM CABLE COVER (BLACK FINISH)
CREDENZA DOOR GLIDE (TOP OR BOTTOM)
SOFT CLOSE 3D CUPBOARD HINGE
CASTOR WHEEL TO SUIT MOBILE PEDESTAL
ADJUSTABLE LEVELLING FOOT

## STELLA PILOT RANGE SPARE PARTS:

### PRODUCT DESCRIPTION

CREDENZA PUSH LOCK (CL2 - 2 KEYS, SILVER FINISH)
MOBILE PEDESTAL LOCK (CL2 - 2 KEYS, SILVER FINISH)
STATIONERY CUPBOARD LOCK (CL2 - 2 KEYS, SILVER FINISH)
DOOR HANDLE (SATIN FINISH)
60MM CABLE COVER (BEECH FINISH)
CREDENZA DOOR GLIDE (TOP OR BOTTOM)
STANDARD CUPBOARD HINGE
CASTOR WHEEL TO SUIT MOBILE PEDESTAL
ADJUSTABLE LEVELLING FOOT

# SOFT WIRING COMPONENTS



## VL1802R\*: DUAL ROTATED GPO

- Dual Auto Switched Power Module (Rotated)
- Soft-wired GPO (compatible with 3m Starter Cable or Link Cable installation)
- Requires GPO Clip to connect to Wire Cable Basket
- Colour: Black (B) or White (W)



## VL1804R\*: QUAD ROTATED GPO

- Quad Auto Switched Power Module (Rotated)
- Soft-wired GPO (compatible with 3m Starter Cable or Link Cable installation)
- Requires GPO Clip to connect to Wire Cable Basket
- Colour: Black (B) or White (W)



## VLWGCB\*: GPO MOUNTING CLIP

- Plastic modular GPO Mounting Clip used to connect Dual or Quad GPO to Wire Cable Basket
- Includes countersunk pre-drilled holes to screw directly to surfaces for easy mounting
- Colour: Black (B) or White (W)



## VLWGC45D\*: 45 DEGREE DATA

- Clip on 45 degree data tile - clips directly to Wire Cable Basket
- Provides a fast install cable management solution to terminate data cabling under the desk top
- Colour: Black (B) or White (W)



## VL84011\*: STARTER PLATE

- Single Starter Plate - 20amp - Wall Mount
- Requires licensed electrician for installation and testing
- Colour: Black (B) or White (W)



## VL84012\*: DUAL STARTER PLATE

- Dual Starter Plate 20Amp Single Circuit - Wall Mount
- Requires licensed electrician for installation and testing
- Colour: Black (B) or White (W)



**VLT5A30\*: 3M STARTER CABLE**

- 3000mm 20A starter lead
- 10A plug to 20amp Tag Installation coupler with Slimline Integrated Thermal Overload
- Thermal overload 300mm in from plug/socket
- Colour: Black (B) or White (W)



**VL5205\*: 500MM LINK CABLE**

**VL5210\*: 1000MM LINK CABLE**

**VL5215\*: 1500MM LINK CABLE**

**VL5220\*: 2000MM LINK CABLE**

**VL5225\*: 2500MM LINK CABLE**

**VL5230\*: 3000MM LINK CABLE**

- Soft-wiring link cables to connect power supply to multiple workstations
- Fast installation solution with plug-and-play functionality
- Additional sizes available on request (only standard sizes listed above)
- Colour: Black (B) or White (W)



**CT12S\*: 1250MM CABLE BASKET**

**CT15S\*: 1550MM CABLE BASKET**

**CT17S\*: 1750MM CABLE BASKET**

- 50mm x 50mm wire cable basket (single tier)
- Each wire basket is supplied with two single tier mounting brackets (spare brackets can be ordered separately)
- Available in sizes ranging from 650mm to 1750mm long
- Colour: Black (B) or White (W)
- Pictured with Quad GPO (not included in price)



**CT12D\*: 1250MM CABLE BASKET**

**CT15D\*: 1550MM CABLE BASKET**

**CT17D\*: 1750MM CABLE BASKET**

- 50mm x 50mm wire cable basket (dual tier)
- Dual baskets are supplied with two dual tier mounting brackets (spare brackets can be ordered separately)
- Available in sizes ranging from 650mm to 1750mm long
- Colour: Black (B) or White (W)
- Pictured with Quad GPO + Data Tiles (not included in price)



**VNDSAUT10D\*: NOVA DUO RAIL**

- Above desk power rail with 1x GPO, USB C/A Charge Module (30W shared)
- 1000mm TAG Lead With L3D Splitter included
- Fast install pre-installed clamp design
- Colour: Black (B) or White (W)



**VN TSAUAT10D\* NOVA TRIO RAIL**

- Above desk power rail with 2x GPO, USB C/A Charge Module (30W shared)
- 1000mm TAG Lead With L3D Splitter included
- Fast install pre-installed clamp design
- Colour: Black (B) or White (W)



# LAYOUT PLANNER

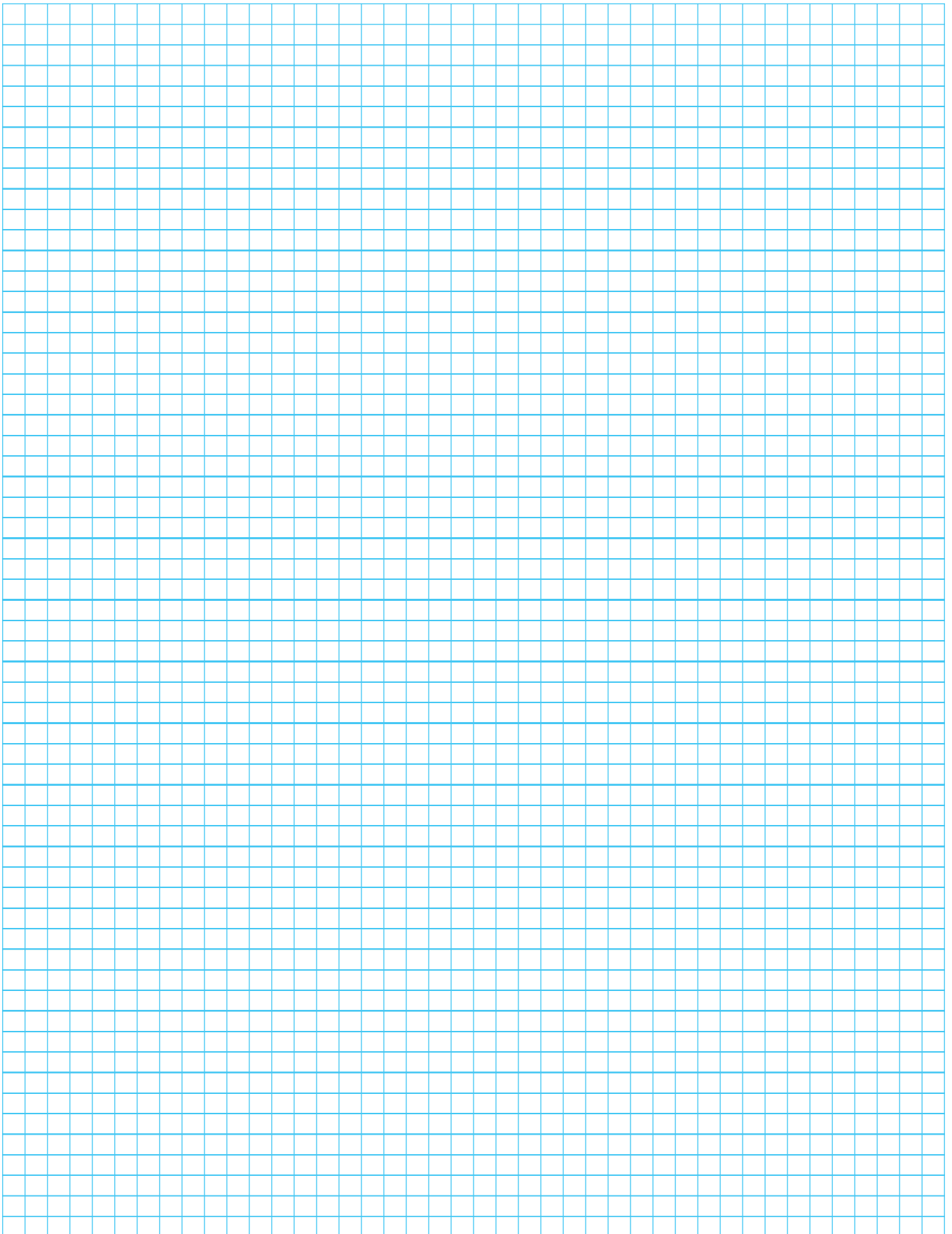

# QUOTE SUMMARY

<b>CUSTOMER / BUSINESS NAME</b>	
<b>CONTACT NAME</b>	
<b>PHONE</b>	
<b>EMAIL</b>	
<b>ADDRESS</b>	
<b>DATE</b>	

<b>PRODUCT DESCRIPTION</b>	<b>COLOUR</b>	<b>QUANTITY</b>	<b>UNIT \$</b>	<b>TOTAL \$</b>
			<b>TOTAL</b>	

